



B6 Refrigerant Circuit Joining Technologies

Repair of refrigeration appliances with Lokring series 00

Length: 60 minutes

Theory / demonstration

Agenda B6

☒ Lokring vs Brazing - Advantages

Areas of application – Series 00

Functional principle

Repair possibilities

Technical specifications

Test laboratory

Assembly tools

Accessories

Lokprep

Assembly instructions

Refrigerant circuit commissioning

Lokring vs Brazing

Advantages

- Generally suitable where brazing is not permitted
- No brazers certification required
- Suitable for flammable refrigerants
- Applicable at appliances location with narrow space
- Customer-friendly onsite service with reduced logistics costs
- Clean, fast and reliable
- Assembly possible in high combustion areas, even with heavy foot traffic or during business operations
- Simple assembly without power connection
- No heavy brazing equipment necessary
- No brazing related quality problems



© Vulkan Lokring

Agenda B6

Lokring vs Brazing - Advantages

☒ Areas of application – Series 00

Functional principle

Repair possibilities

Technical specifications

Test laboratory

Assembly tools

Accessories

Lokprep

Assembly instructions

Refrigerant circuit commissioning

Areas of application

- Household refrigeration appliances (refrigerators, freezers, wine coolers)
- Ready-to-use refrigeration equipment (refrigeration cabinets, bars, lockers, chillers)
- Refrigeration equipment for catering (sales counter refrigerators, flow-through coolers, portable cooling systems)



© Vinoteca



© Midea



© rvpartscountry



© Foster



© Huasheng-Europe



© AHT



© lgcoll.se

Agenda B6

Lokring vs Brazing - Advantages

Areas of application – Series 00

☒ Functional principle

Repair possibilities

Technical specifications

Test laboratory

Assembly tools

Accessories

Lokprep

Assembly instructions

Refrigerant circuit commissioning

Functional principle

Components



- ① Joint
- ② Rings
- ③ Lokprep (anaerobic sealant)

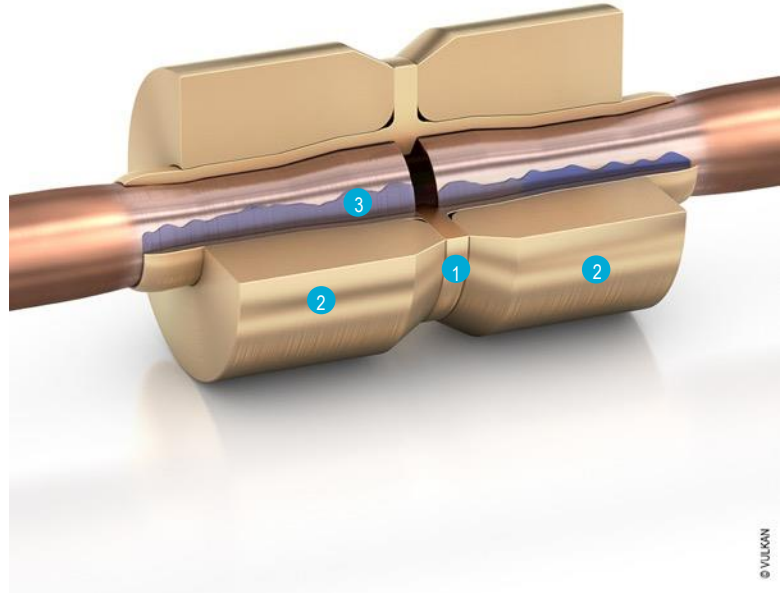

© Vulkan Lokring

Functional principle

Areas of the connection

- A Insertion area
- B Stabilisation and sealing area
- C Main sealing area

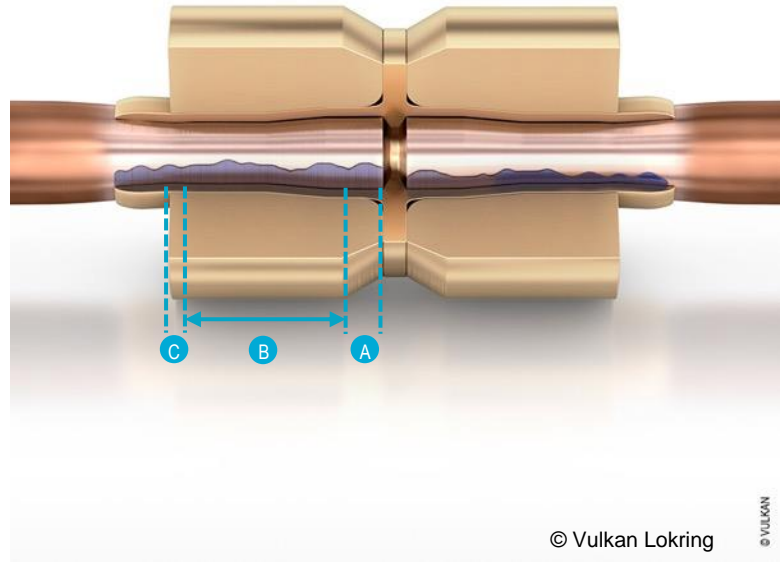

Agenda B6

Lokring vs Brazing - Advantages

Areas of application – Series 00

Functional principle

✕ Repair possibilities

Technical specifications

Test laboratory

Assembly tools

Accessories

Lokprep

Assembly instructions

Refrigerant circuit commissioning

Repair possibilities

Overview

- Replace a compressor
- Replace a filter-dryer
- Replace a charging tube
- Repair leaky brazed connections

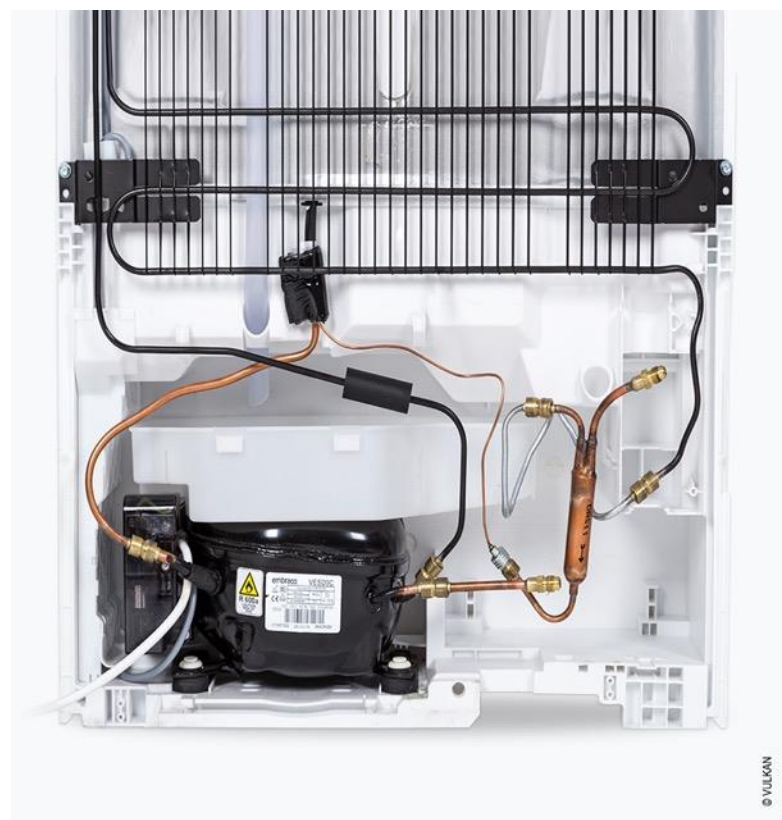

© VULKAN

© Vulkan Lokring

Repair possibilities

Material combinations

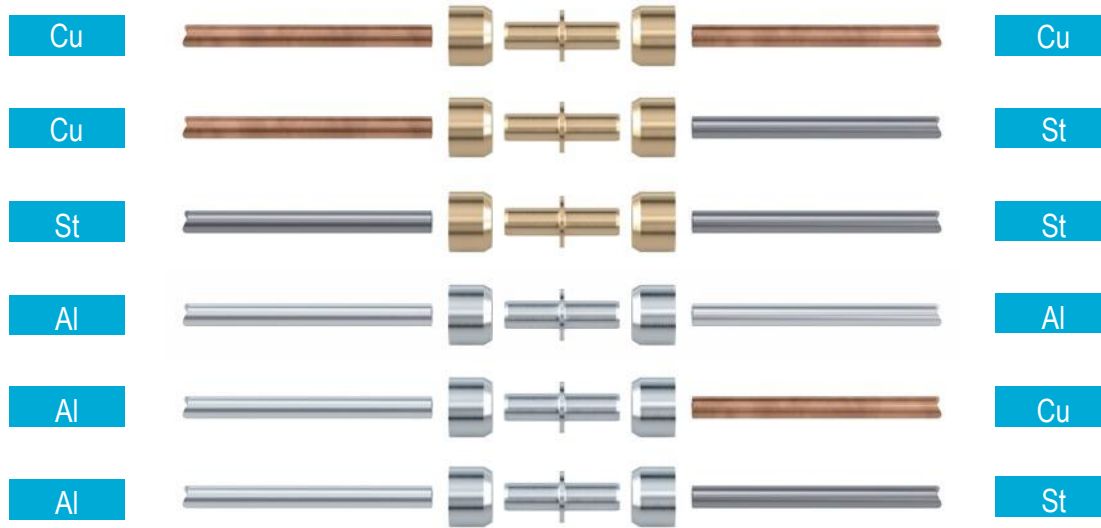

© Vulkan Lokring

Repair possibilities

Starter kit

For a perfect start in the world of repairs to plug-in refrigeration equipment.

- Hand assembly tool
- Assembly jaws
- Lokprep
- Sandpaper
- Filter-dryers
- Straight connectors
- Straight reducing connectors



© VULCAN

© Vulkan Lokring

Repair possibilities

Filter-Dryer section

- 1 Liquid line > Dryer



- 2 Dryer > Capillary tube



© Vulkan Lokring

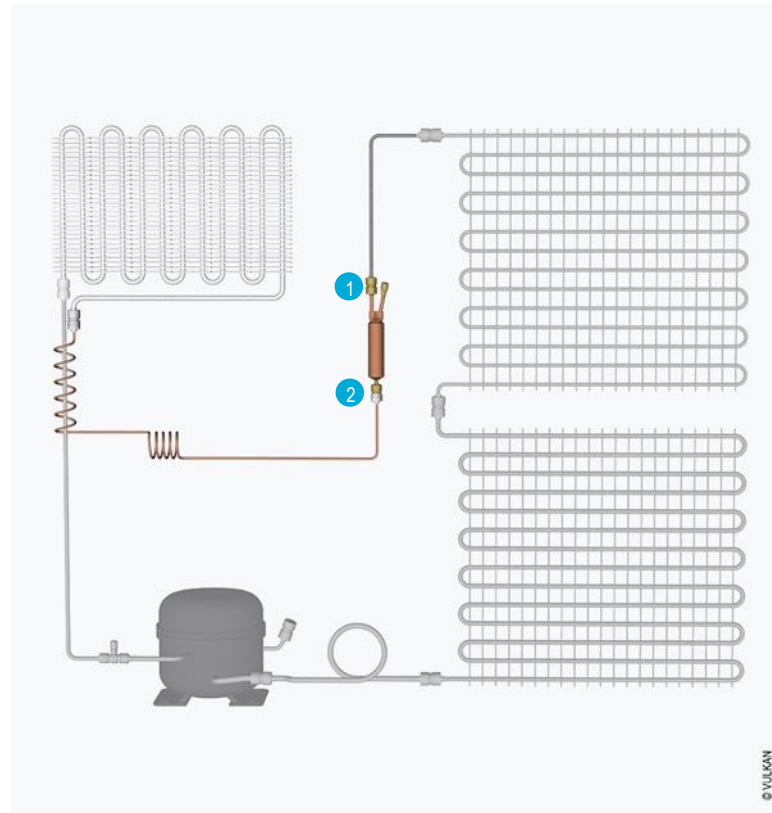

© VULKAN

© Vulkan Lokring

Repair possibilities

Filter-dryers

- Specially designed for Lokring application.
- For all HC and HFC refrigerants.
- Protects the refrigeration circuit against moisture, acids and dirt particles.
- Desiccant: XH-9

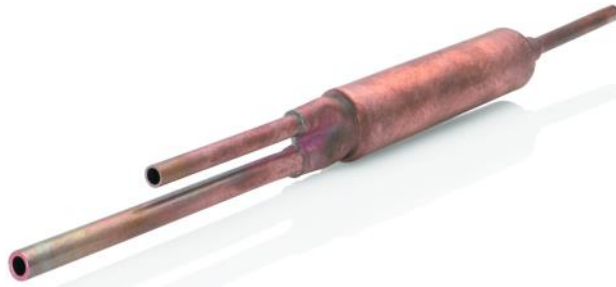

© Vulkan Lokring



© Vulkan Lokring

Repair possibilities

Evaporator section

- 3 Capillary tube > Evaporator



- 4 Evaporator > Suction line



© Vulkan Lokring

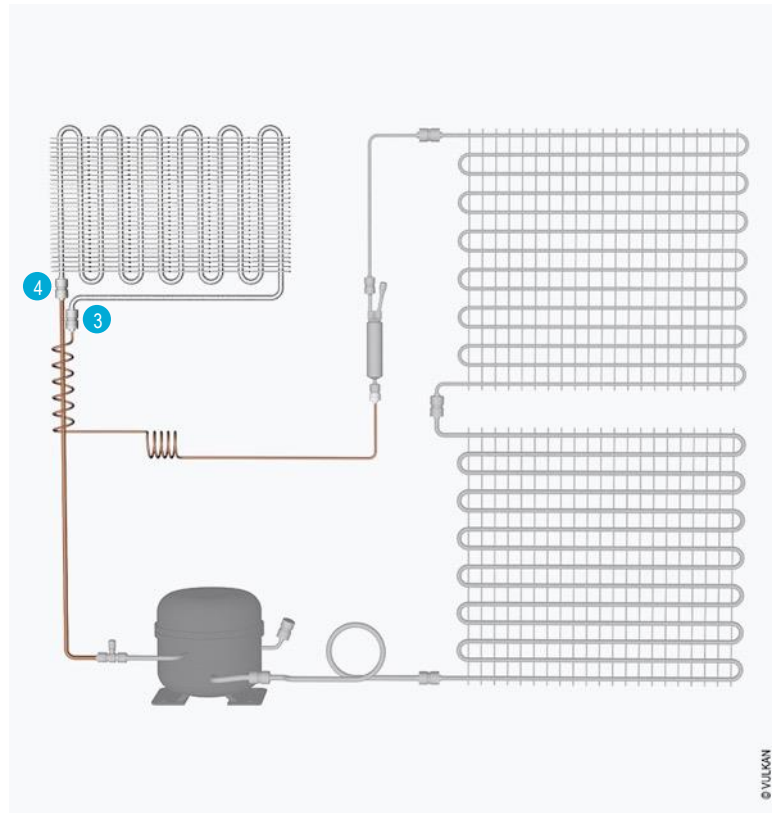

© Vulkan Lokring

Repair possibilities

Condenser section

- 5 Back plate condenser
 - > Liquid line
- 7 Hot gas line
 - > Side plate condenser



- 6 Side plate condenser
 - > Back plate condenser

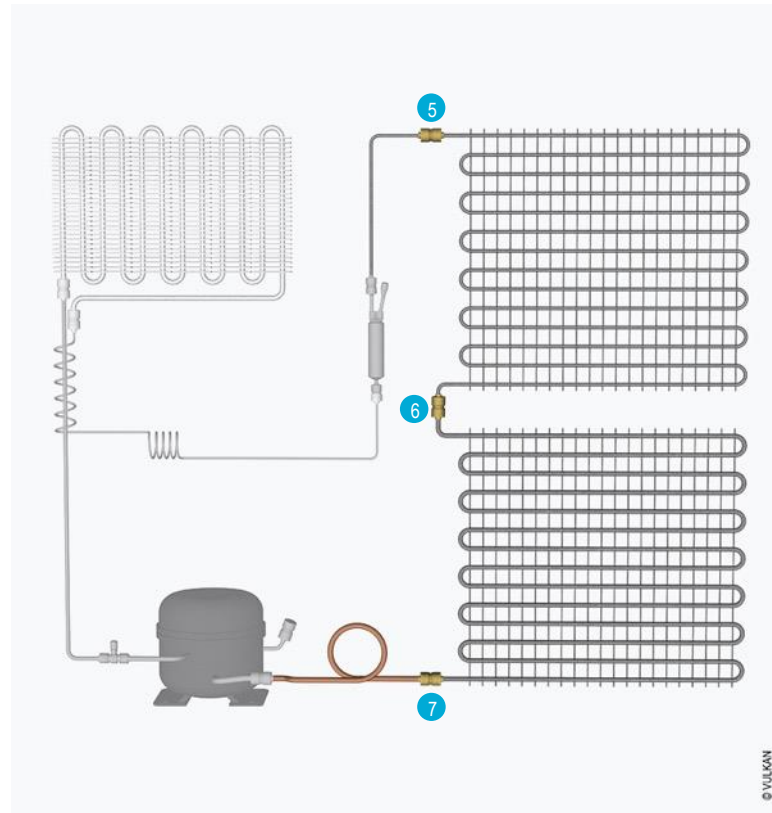

Repair possibilities

Compressor section

- 8 Charging tube with stopper



- 8 Charging tube with 1/4" schrader valve



© Vulkan Lokring

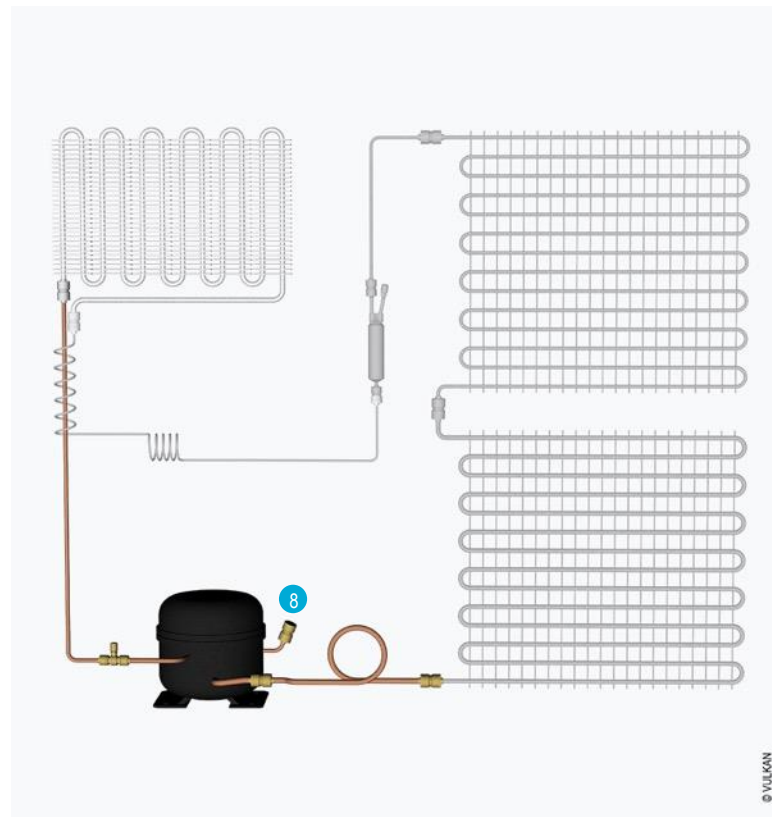

© VULKAN

Repair possibilities

Compressor section

- 9 Compressor > Hot gas line



- 1 Suction line > Compressor



© Vulkan Lokring

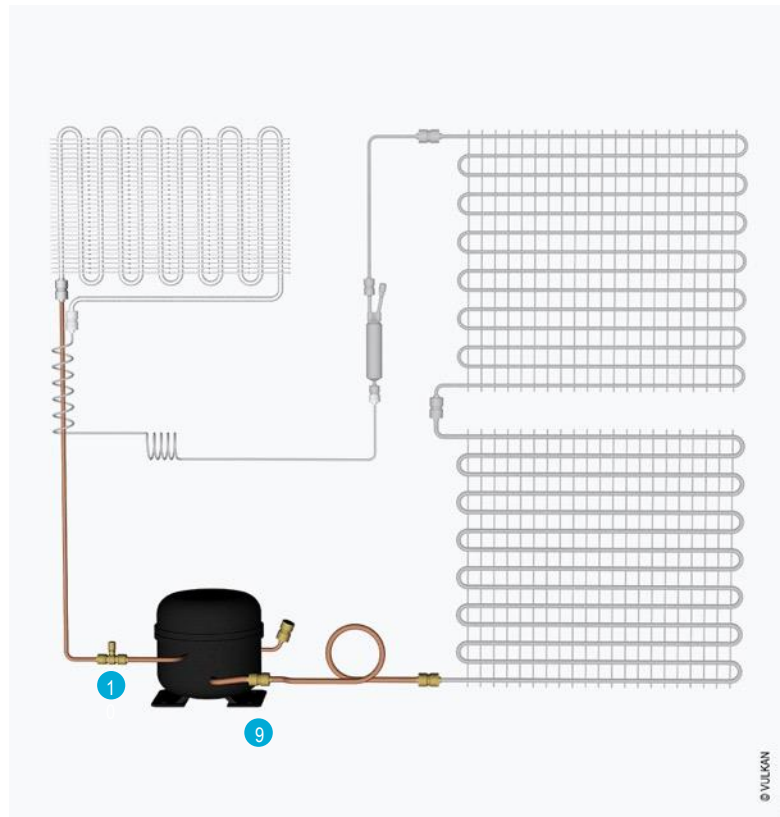

© VULKAN

Agenda B6

Lokring vs Brazing - Advantages

Areas of application – Series 00

Functional principle

Repair possibilities

✘ Technical specifications

Test laboratory

Assembly tools

Accessories

Lokprep

Assembly instructions

Refrigerant circuit commissioning

Technical specifications

Lokring connectors type 00



Lokring tube connections are available in material of brass and aluminium and in tube diameter ranges of 1.6 mm to 11 mm (1/16" to 3/8") for brass and 2 to 9 mm (5/64" to 5/16") for aluminium.

Approvals	TÜV UL (File SA12004)
Reference standards	EN 378-2:2016 and EN ISO 14903:2017-12
Max. operating pressure	25 bar (360 psi)
Admissible refrigerants	HFC, HC, not suitable for CO ₂ and NH ₃
Temperature range	-50°C up to 150°C (-58°F up to 302°F)
Minimum tube wall thickness	0.5 mm

Agenda B6

Lokring vs Brazing - Advantages

Areas of application – Series 00

Functional principle

Repair possibilities

Technical specifications

✕ Test laboratory

Assembly tools

Accessories

Lokprep

Assembly instructions

Refrigerant circuit commissioning

Test laboratory

Pressure test (static)

The Lokring connection is always stronger than the tube.



© Vulkan Lokring

Agenda B6

Lokring vs Brazing - Advantages

Areas of application – Series 00

Functional principle

Repair possibilities

Technical specifications

Test laboratory

 Assembly tools

Accessories

Lokprep

Assembly instructions

Refrigerant circuit commissioning

Assembly tools

Loktool HMRK-V

- Specially developed for the Lokring assembly.
- Patented lever mechanism for assembly with minimum effort.
- Assembly jaws are easy to change for different tube diameters.
- Both handles bend for use in hard-to-reach areas.

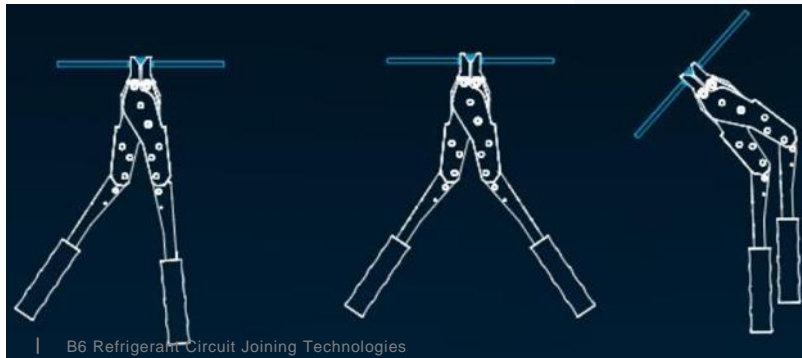

© VULKAN

© Vulkan Lokring

Assembly tools





Assembly jaws

- Suitable for the LOKTOOL HMRK-V and HMRK-L hand assembly tools.
- Suitable for double-sided assembly of LOKRING type 00 connections.
- MB 8 for tube outer- \varnothing 1.6 – 8.5 mm (1/16" – 5/16")
- MB 10 for tube outer- \varnothing 9 – 11 mm (3/8")
- MB 12 for tube outer- \varnothing 12 - 13 mm (1/2")



© Vulkan Lokring

Assembly tools

Loktool VME	Loktool NTR-8	Loktool NAV 11	Lokring NAV-E
			
<p>For single-sided pre-assembly of Lokring connector type 00, sizes 3 to 8</p>	<p>For assembling a T-branch. For assembly, the insert is simply inserted into the assembly jaw.</p>	<p>Basic tool for assembling Lokring NAV connections</p>	<p>Assembly insert for NAV 11 assembly tool for assembling Lokring NAV connections, sizes 6 to 9.53</p>

© Vulkan Lokring

Agenda B6L

Lokring vs Brazing - Advantages

Areas of application – Series 00

Functional principle

Repair possibilities

Technical specifications

Test laboratory

Assembly tools

✕ Accessories

Lokprep

Assembly instructions

Refrigerant circuit commissioning

Accessories

Copper cleaning



© Vulkan Lokring

Abrasive mat

- For cleaning tube ends without scratching.
- Suitable for all surfaces.
- Solvent-resistant.
- Dimensions: 158 mm x 224 mm



© Vulkan Lokring

Sand paper (abrasion resistant)

- For cleaning tube ends.
- Grain 120
- Dimensions: 230 mm x 280 mm







© ITE Tools

Deburrer

- For removing of burrs
- For all copper and aluminium tubes

Accessories

Tools

Toobe cutting plier	Capillary tube cutter	Piercing plier	Pinch-off plier	Quick copper tube connector
 <p>© Vulkan Lokring</p>				
<p>For cutting aluminium, copper and steel tubes. Wall thicknesses up to 1 mm. Diameter range: 4 to 12.7 mm (5/32" to 1/2") A 120° rotation is sufficient to make the cut.</p>	<p>For clean cutting of capillary tubes. No reduction of inner diameter. Suitable for all capillary tube diameters.</p>	<p>For recovering refrigerant from defective but still pressurised refrigeration circuits. Suitable for copper tubes. For tube outer diameter of 6 mm (1/4"). Hose connection: 1/4" SAE</p>	<p>For pinching off charging tubes. Diameter range: up to 10 mm (3/8")</p>	<p>Quick coupling for straight copper tubes. Quick connection inserts and gaskets.</p>

Agenda B6

Lokring vs Brazing - Advantages

Areas of application – Series 00

Functional principle

Repair possibilities

Technical specifications

Test laboratory

Assembly tools

Accessories

☒ Lokprep

Assembly instructions

Refrigerant circuit commissioning

Lokprep

Lokprep G65

- compensates for any unevenness in the tube surface
- hardens under oxygen exclusion and in contact with free metal ions
- stays elastic
- ensures that every Lokring connection is hermetically sealed
- Respect the curing time (min. 10 minutes) of the Lokprep 65G.

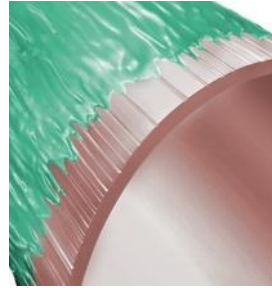

© Vulkan Lokring

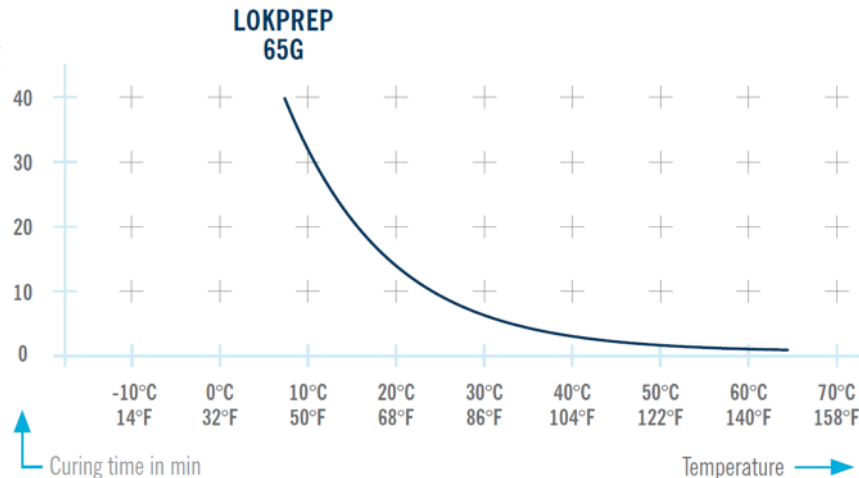

Agenda B6

Lokring vs Brazing - Advantages

Areas of application – Series 00

Functional principle

Repair possibilities

Technical specifications

Test laboratory

Assembly tools

Accessories

Lokprep

☒ Assembly instructions

Refrigerant circuit commissioning

Assembly instructions

Clean up the tube ends

Clean the tube ends in a rotational motion to ensure that they are clean and free from paint or other surface impurities.

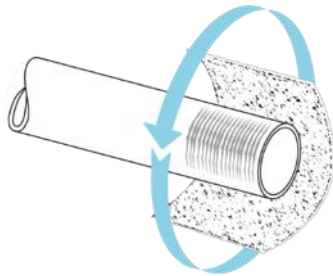

© Vulkan Lokring

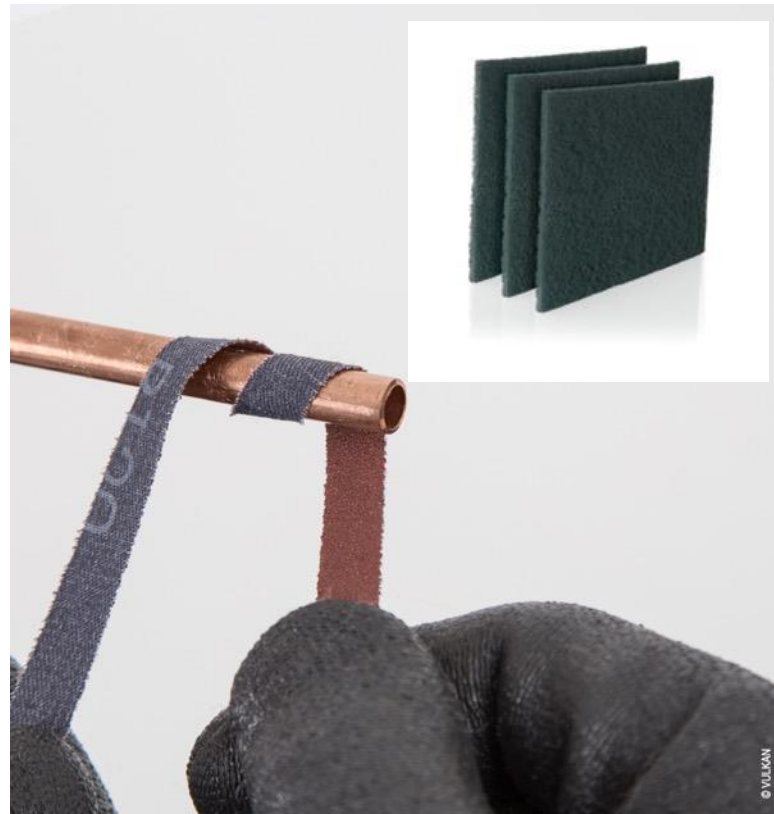

Assembly instructions

Calliper

- Determine the outer tube diameter \varnothing using a digital callipers.
- Select the required connector.



© HEAT GmbH

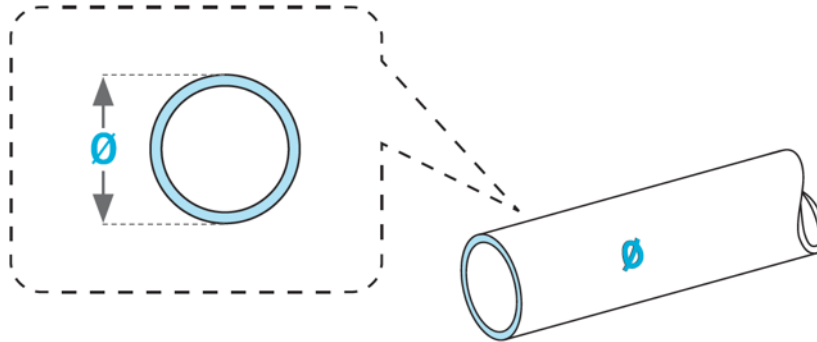

Assembly instructions

Apply Lokprep

- Apply Lokprep 65G onto the tube ends.
- Curing time of Lokprep starts after it is applied onto the tube.

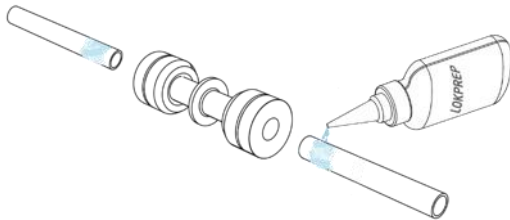

© Vulkan Lokring

Assembly instructions

Insert tubes

- Insert both tube ends into the Lokring connector until the tubes reach the inner stop.
- Rotate the Lokring connector through 360° to distribute the Lokprep 65G evenly.
- Respect the correct curing time of the Lokprep 65G.
- **Make the Lokring connection within 20 seconds after applying Lokprep!**

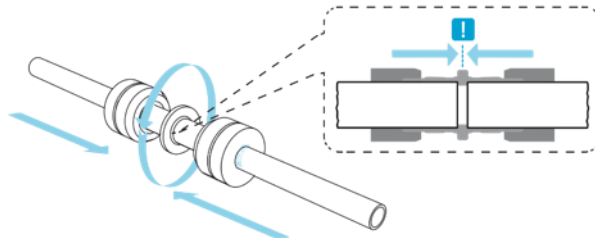

© Vulkan Lokring

Assembly instructions

Press the rings onto the joint

Press the tube connection until the rings of the Lokring connector are flush to the assembly stop of the Lokring connector.

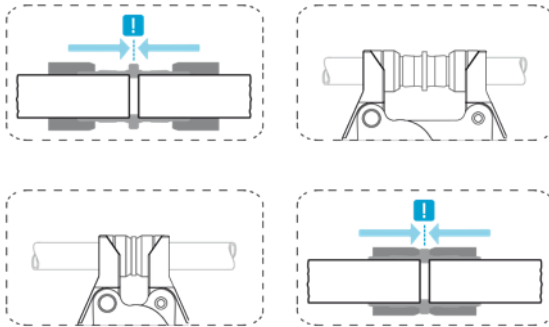

© Vulkan Lokring

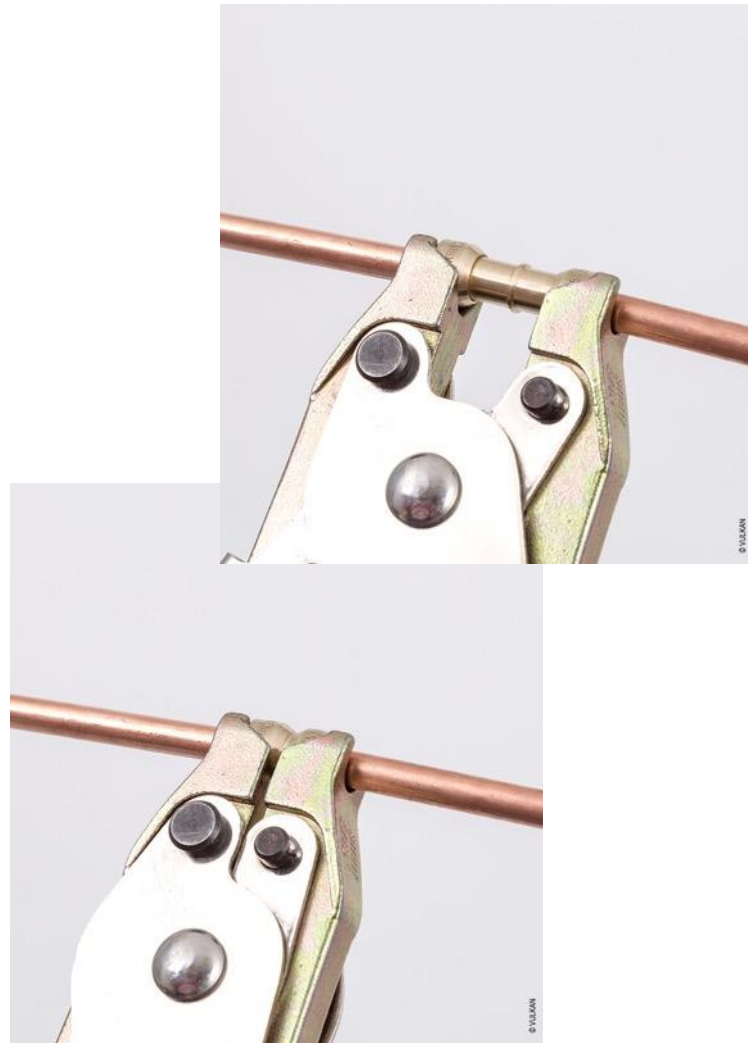

Assembly instructions

Complete the connection





- Respect the curing time (min. 10 minutes) of the LOKPREP 65G.
- The refrigerant circuit is now prepared for:
 - pressure testing
 - evacuation
 - charging with refrigerant
 - operation





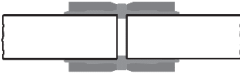

© Vulkan Lokring

Assembly instructions

Examples as assembly aid

			
<p>Wrong: Rings have not been pressed through to the assembly stop.</p>	<p>Right: Rings have been pressed flush to the assembly stop.</p>	<p>Wrong: The bending point is too close to the joint end.</p>	<p>Right: The tube has to be led straightly out of the joint.</p>

			
<p>Wrong: Assembly jaws are not set in place correctly.</p>	<p>Right: Assembly jaws are set flush correctly.</p>	<p>Wrong: The tube is not pushed in as far as the inner stop.</p>	<p>Right: Push the tube in until you can feel the inner stop.</p>

Agenda B6L

Lokring vs Brazing - Advantages

Areas of application – Series 00

Functional principle

Repair possibilities

Technical specifications

Test laboratory

Assembly tools

Accessories

Lokprep

Assembly instructions

 Refrigerant circuit commissioning

Refrigerant circuit commissioning

Execute regular refrigerant circuit servicing activities by applying best servicing practices.

- Functional check of a fridge
- Discharge of the refrigerant (HC venting)
- Recovery of refrigerant
- Repair with Lokring at several connecting points of the refrigerant circuit
- Evacuation
- Charging of refrigerant using a sensitive weighting scale
- Sealing of the refrigerant circuit
- Functional check of the repaired fridge
- Leak detection

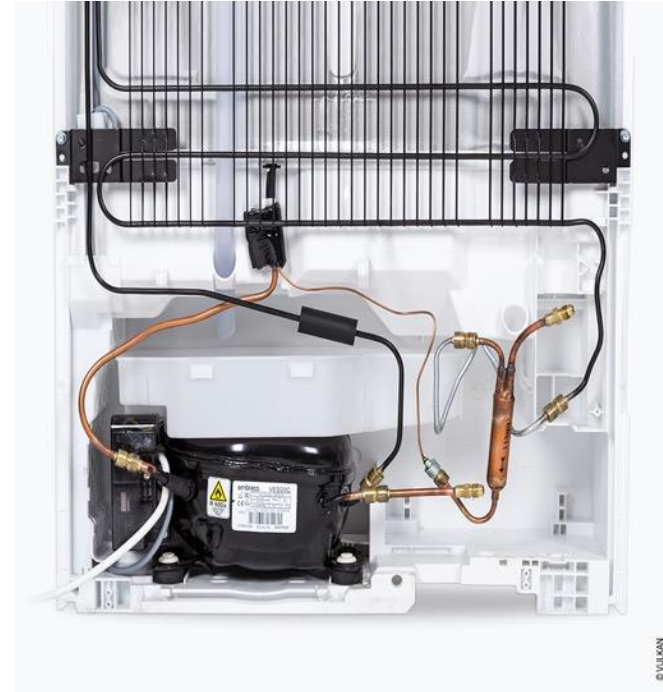

© Vulkan Lokring

Thank you for your attention



As a federally owned enterprise, GIZ supports the German Government in achieving its objectives in the field of international cooperation for sustainable development.

Published by:

Deutsche Gesellschaft für
Internationale Zusammenarbeit (GIZ) GmbH

Registered offices
Bonn and Eschborn

GIZ Proklima

Contact:

Bernhard Siegele
E bernhard.siegele@giz.de
T +49 6196 79-1968
I www.giz.de/proklima



Author:

Rolf Hühren, HEAT GmbH, Königstein, Germany

E Rolf.huehren@heat-international.de
www.heat-international.de

Photo credits/sources:

Pictures for this module have been provided by Vulkan Lokring, Perkeo, Rothenberger, ITE tools, Conex/Bönninger and Rolf Hühren.

URL links:

Responsibility for the content of external websites linked in this publication always lies with their respective publishers. GIZ expressly dissociates itself from such content.

GIZ is responsible for the content of this publication.

Consultancy services provided by:



HEAT GmbH
www.heat-international.de

**Deutsche Gesellschaft für
Internationale Zusammenarbeit (GIZ) GmbH**

Registered offices
Bonn and Eschborn

Friedrich-Ebert-Allee 36 + 40
53113 Bonn, Germany
T +49 228 44 60 - 0
F +49 228 44 60 - 17 66

Dag-Hammarskjöld-Weg 1 - 5
65760 Eschborn, Germany
T +49 61 96 79 - 0
F +49 61 96 79 - 11 15

E info@giz.de
I www.giz.de