



Module A: Placing and mounting of AC system components

Authors: Anthony Darlow, Rolf Hühren, HEAT GmbH



Introduction to the Refrigeration and air conditioning training guide

The refrigeration, air-conditioning and heat pump (RACHP) sector is facing many changes over the next few years. Many refrigerants currently used will be phased-out or phased-down in the near future under the Montreal Protocol and its Kigali Amendment because of their harmful effects to the environment. This includes their ozone-depleting and climate-damaging properties. Additionally, the energy efficiency of a unit is becoming more and more important. For skilled workers in the RACHP sector, this results in many challenges as new technologies are entering the market.

There are several risks from working in the RACHP sector. On the one hand, environmental harm can be caused through the release of ozone-depleting and climate-damaging refrigerants during operating and servicing. On the other hand, the personal safety of the skilled workers handling the equipment and refrigerants as well as the safety of users of equipment has to be ascertained. Dangers include intoxication, refrigerant burns, suffocation, fire, and explosion, as well as electrical faults leading to fires and electrical shock or bad practice installations causing refrigerant leakages.

The reduction of greenhouse gases such as hydrofluorocarbons (HFCs) typically requires a combination of technology change, regulatory action and human capacity development. The technical characteristics of refrigerants change dramatically in view of their flammability, toxicity and/or operating pressure level with the transition from the predominantly used hydrochlorofluorocarbons (HCFCs) and (saturated) HFCs with high global warming potential (GWP) to climate friendly refrigerants, including natural refrigerants and a number of unsaturated HFCs (HFOs) with very low GWP.

This module on placing and mounting of AC system components is one part of a series of training modules on best practice guidelines in refrigeration and air conditioning, published by GIZ. Together, the modules form the basis for qualified work of skilled workers and address the mentioned challenges in the RACHP sector. The module content is based on international standards for the training of RACHP skilled workers as well as product and general RACHP safety standards. The set of modules range from basic knowledge necessary for skilled workers as well as more advanced qualifications involving the refrigerant circuit and professional level modules (see figure below), for example on energy efficient design or ammonia refrigeration. A good basis is necessary before starting on advanced modules.

The modules can be used to support a national quality infrastructure for skilling of refrigeration and air conditioning technicians, based on approved best practice codes and international standards. Essential instruments for its implementation include qualification, certification, accreditation, registration, monitoring, and financial incentive schemes. Certification of skilled workers and companies is essential to sustainably increase competencies in the RACHP sector. Certification should always be linked to examination by an accredited institution and registration in a country database. Previously determined skills to assess are the basis for certification and an example is contained in the presented modules. The content of the modules is based on skills to assess in standards ISO 22712/EN 13313: Refrigerating systems and heat pumps – Competence of personnel.

Module A: Placing and mounting of AC system components

The following modules are available:

Module A	Placing and mounting of AC system components
Module B	Refrigerant circuit joining technologies
Module C	The basics: Basic knowledge in thermodynamics, refrigerants and lubricants
Module D	Electrical basics for refrigeration installations and safety
Module E	Environmental impacts
Module F	Hermetisation (sealed system design)
Module G	Refrigerant recovery, recycling, and reclaim
Module H	Installation and commissioning
Module I	Operations and maintenance
Module J	Safe application of hydrocarbon refrigerants
Module K	Energy efficiency in refrigeration and air conditioning
Module L	Design and testing of RACHP appliances and systems
Module M	Carbon dioxide (CO ₂) in refrigeration
Module N	An introduction to ammonia (NH ₃) in refrigeration

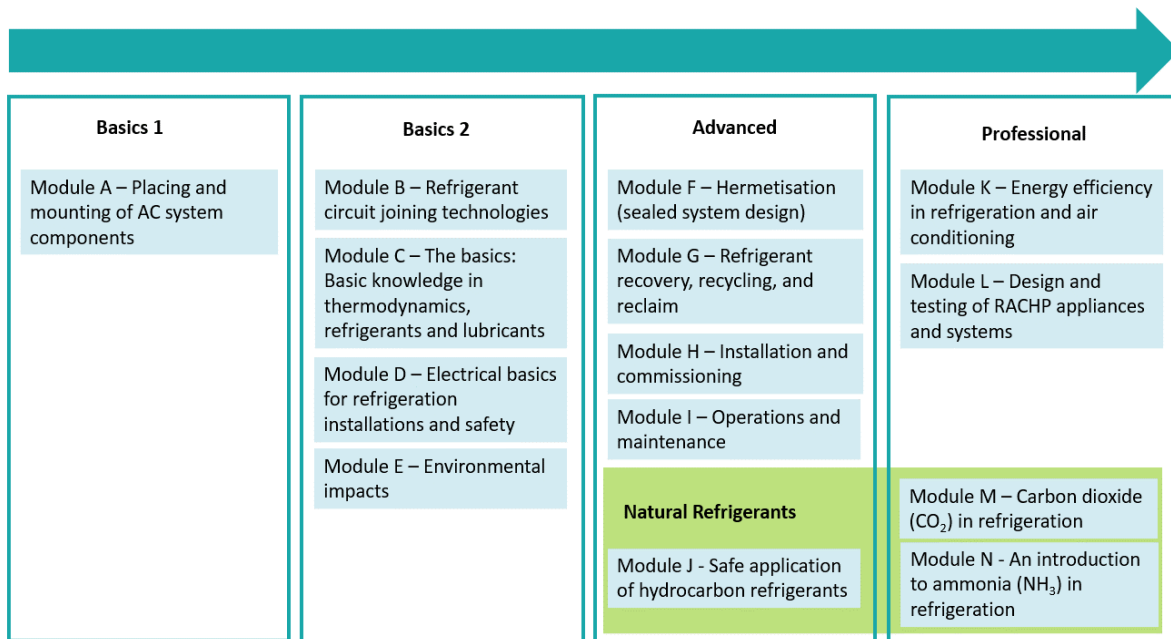

In addition to this handbook, further material for trainers is available, such as trainer manuals, PowerPoint presentations, training agendas and handouts.

Disclaimer

Reasonable efforts have been taken to ensure that the information or advice is reliable, correct, accurate and accords with current standards as at the date of publication. The information or advice contained in this document is intended for use only by persons who have had adequate technical training in the field to which the code of practice relates. The document has been compiled as an aid only, and the information or advice should be verified before it is applied by any person. The user should also establish the applicability of the information or advice in relation to any specific circumstances.

To the maximum extent permitted by law, the GIZ and its consultants and trainers:

1. disclaim all responsibility and all liability (including without limitation, liability in negligence) for all expenses, losses, damages and costs, whether direct, indirect, consequential or special you might incur as a result of the information in this publication being inaccurate or incomplete in any way, and for any reason; and
2. exclude any warranty, condition, guarantee, description or representation in relation to this publication, whether express or implied.

In all cases, the user should also establish the accuracy, currency and applicability of the information or advice in relation to any specific circumstances and must rely on his or her professional judgement at all times. The user is furthermore responsible to inform themselves about the national legislation and directives and to act accordingly.

Pictures for this module have been provided by Tony Darlow or Rolf Hühren unless otherwise noted.

Module A: Placing and mounting of AC system components

Symbols

The following symbols are used to structure the text and highlight important messages:



Incorrect uses or work processes are highlighted by a red x.



Correct uses or work processes are highlighted by a green check mark.



See chapter xxx

Textbox referring the reader to a different chapter



How to

Referring to instructions describing work routines



Safety relevant message



Message with direct relevance to flammable refrigerants

Other signs used in the document:



Electricity



Explosive materials



Asphyxiation

Black text boxes highlight specific topics or additional information.

Content

List of abbreviations.....	10
A1 Introduction	11
A2 Ensuring safety.....	13
A2.1 Safety bans and warnings	13
A2.2 Electrical safety	13
A2.3 Personal protective equipment	14
A2.4 Safe handling of installation tools and equipment.....	14
A3 Installation site.....	15
A3.1 Ambient temperature	15
A3.2 Installation considerations for indoor unit	15
A3.3 Installation considerations for outdoor unit.....	16
A3.4 Installation site draft sketch	16
A4 List of required materials and tools	19
A5 Step by step placing and mounting of a window AC	20
A5.1 Supplies check.....	20
A5.2 Preparation, positioning and installation of window AC	20
A5.3 Window AC installation protocol	22
A6 Step by step placing and mounting of a split AC	24
A6.1 Split AC supplies check.....	24
A6.2 Indoor unit	24
A6.3 Electrical connections	27
A6.4 Outdoor unit	29
A6.5 Split AC installation protocol.....	34
A6.6 Post installation check-up.....	36
A7 Refrigerant circuit tubing.....	36
A7.1 Importance of good pipework	36
A7.2 Copper tube	37
A7.3 Bending copper tube.....	38
A7.4 Oil traps for compressor oil-return	43
Bibliography	46

Figures

Figure 1: Window AC System showing airflows through system (Source: Pbroks13/Wikimedia).....	11
Figure 2: Example of split AC system installation (Source: GIZ).....	12
Figure 3: Commonly used safety signage / labels.....	13
Figure 4: Personal protective equipment	14
Figure 5: Exemplary relation of outdoor temperature and cooling capacity (Source: GREE).....	15
Figure 6: Example of installation site draft sketch (Source: HEAT GmbH).....	17
Figure 7: Example of correct location of indoor unit (Source: HEAT GmbH)	18
Figure 8: Example of adequate outdoor unit wall installation (Source: HEAT GmbH)	19
Figure 9: Example of inadequate outdoor unit installation (Source: HEAT GmbH)	19
Figure 10: Positioning dimensions when fitting a window AC (Source: HEAT GmbH).....	21
Figure 11: Bracket (Source: HEAT GmbH)	24
Figure 12: Indoor unit (Source: HEAT GmbH)	24
Figure 13: Outdoor unit (Source: HEAT GmbH)	24
Figure 14: Example of master plate for installation orientation (Source: http://aroundhomediy.com).....	25
Figure 15: Mounting the installation bracket (Source: http://aroundhomediy.com)	25
Figure 16: Details for drilling and preparation of the hole through wall (Source: HEAT GmbH)	26
Figure 17: Drilling the tubing hole through the wall (Source: http://aroundhomediy.com)	26
Figure 18: Indoor unit goes towards bracket, covering the hole through the wall (Source: http://aroundhomediy.com)	27
Figure 19: Example of electrical connections between the indoor unit and the outdoor unit (Source: GREE).....	28
Figure 20: Ideal positioning of electrical cable and pipes through hole in the wall, all tubes are insulated (Source: HEAT GmbH).....	29
Figure 21: Example of service valves fitted to the outdoor unit (Source: www.espasogutma.com)	30
Figure 22: Example of outdoor unit showing typical refrigerant pipe connections (Source: HEAT GmbH)	30
Figure 23: Indication of service valve elements and designation unit (Source: www.espasogutma.com).....	30
Figure 24: Outdoor unit electrical and pipe connections cover (Source: HEAT GmbH)	31
Figure 25: Example of outdoor unit showing service valves and interior components (Source: HEAT GmbH).....	31
Figure 26: Examples of adequate electrical connections in outdoor unit (left) and indoor unit (right) (Source: HEAT GmbH).....	31
Figure 27: Example of inadequate electrical connections - no cable hoes or end splices (Source: HEAT GmbH).....	32
Figure 28: A good bend and a flattened bend (Source: HEAT GmbH)	37
Figure 29: Inadequately handled copper tube (Source: HEAT GmbH)	37
Figure 30: Copper tube bending springs (Source: HEAT GmbH).....	39
Figure 31: Example of triple size tube bender size 1 (1/4"; 5/16", 3/8") (Source: javac.co.uk)	40
Figure 32: Example of triple size tube bender size 2 (3/16", 1/4", 3/8", 1/2") (Source: imperial.com)	40
Figure 33: Individual size tube bender (Source: ITE-Tools).....	41
Figure 34: Angle marks on a tube bender (Source: HEAT GmbH).....	41
Figure 35: Parts of a tube bender (Source: HEAT GmbH)	42
Figure 36: Arrangement of P-trap in suction pipe riser (Source: HEAT GmbH)	44
Figure 37: Arrangement of P-trap and S-trap in suction pipe riser (Source: HEAT GmbH).....	44
Figure 38: Example of invert trap arrangement within the suction pipe (Source: HEAT GmbH)	45

Tables

Table 1 Cooling and heating capacity conversion table	12
Table 2 Installation Protocol (Source: HEAT GmbH).....	23
Table 3 Torque tightening values.....	32
Table 4 Installation protocol for split AC system (Source: HEAT GmbH).....	35

Learning outcomes

In this chapter, you will get: a brief introduction to placing and mounting of window air conditioning systems (window AC) and split air conditioning systems (split AC).

Detailed learning outcomes are described below:

Basics 1 level	
Knowledge	<p>Know and understand</p> <ol style="list-style-type: none"> 1. the installation of AC equipment (split or window type) and preparation for commissioning with a subsequent step, no handling of refrigerants 2. the basic purpose of air conditioning systems 3. the general design features of window type and split air-conditioning systems 4. observation and application of measures for occupational health and safety and accident prevention regulations. 5. observation and application of environmental protection and rational use of material resources and energy. 6. how to plan the installation of a window AC 7. how to plan the installation of a split AC 8. all aspects of correct placement of window ACs and split ACs 9. the requirements of good airflows over AC systems 10. differentiate refrigerant suction pipe from refrigerant injection or liquid pipe
Skills	<p>Be able to</p> <ol style="list-style-type: none"> 11. recognise the relevant safety signs in the AC industry 12. use appropriate PPE when Placing and Mounting AC Components 13. check the installation equipment and materials for damages 14. plan the installation of an AC system 15. mount an AC system to a building 16. install refrigerant piping according to OEM instructions 17. install refrigerant piping insulation 18. electrically interconnect IDU and ODU 19. install and functionally test condensate drain pipes 20. make and check components and pipe supports 21. make a visual and manual inspection of the whole system in accordance with the OEM installation manual 22. carry out a check for leakages (at the joining connections) using a direct leak detection method (bubble test or gas detector) 23. fill in data in the equipment installation protocol

List of abbreviations

Acronym	Definition
AC	Alternating Current
DC	Direct Current
FO	Fully Opened
GHS	Global Harmonized System
GWP	Global Warming Potential
HCFC	Hydrochlorofluorocarbon
HFC	Hydrofluorocarbon
HFO	Hydrofluoroolefin
IDU	Indoor Unit
OD	Outside Diameter
ODU	Outdoor Unit
OEM	Original Equipment Manufacturer
OFDN	Oxygen Free Dry Nitrogen
PPE	Personal Protection Equipment
PVC	Polyvinylchloride
RACHP	Refrigeration, Air Conditioning and Heat Pump
RT	Refrigeration Ton

A1 Introduction

Module A covers the placing and mounting of single split and window air conditioning (AC) systems.

It does NOT include the necessary information to commissioning/decommissioning a system or information needed for handling refrigerant (breaking into the system, charging with refrigerant, topping up with refrigerant or recovering refrigerant are not covered).

Note: Commissioning/decommissioning or any breaking of the refrigerant circuit must not be done by anyone who is not a skilled craftsman, i.e. a competent person according to the following definition:

A **competent person** (skilled craftsman/woman) is one who, due to her/his professional training and experience, has sufficient knowledge in the field of refrigeration technology and of the relevant state health and safety regulations, accident prevention regulations and generally accepted rules of technology to the extent that she/he is able to assess the safe working conditions of refrigeration systems (see Module J, Chapter J4.3.2.4 for further information). According to the standards EN 13313:2011 and ISO 22712:2018, for any refrigerant handling procedures, the competent person has the minimum certification level of category III “Fully Operational” (FO).

Window ACs are installed either through an open window or a hole through an external wall. The air inside the room is cooled as a fan circulates it over the evaporator. The heat extracted from the air is then transferred, by refrigerant, to the condenser, which is located in the part of the system in the outside air. The heat drawn from the interior is dissipated into the environment as a second fan blows outside air over the condenser. Some models of window type air-conditioners may have also air-supply (function).

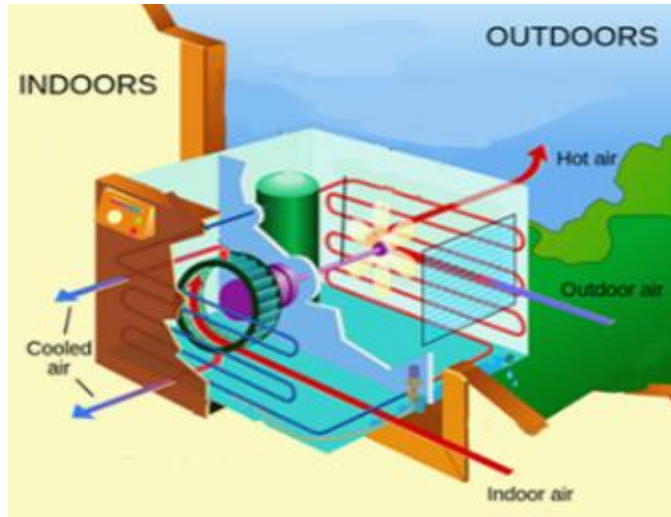

Figure 1: Window AC System showing airflows through system (Source: Pbroks13/Wikimedia)

A **split AC** system consists of an outdoor unit and an indoor unit. The outdoor unit is installed external to the room being cooled, but ideally close to that room. It can be mounted on brackets fitted on a suitable wall or placed on a firm hard base, such as concrete blocks. This unit houses the compressor, condenser coil and the expansion device. The indoor unit is fitted within the room to be cooled and contains the cooling coil, a long tangential fan and air filters. Some models of split type ACs may have also air-supply (function).

Indoor and outdoor unit are interconnected by refrigerant transfer pipes and electrical wiring as per Original Equipment Manufacturer (OEM) installation manual specification. The refrigerant transfer pipes consist of the following:

Module A: Placing and mounting of AC system components

- The liquid or injection pipe (usually the smaller tube), delivering the refrigerant from the outdoor unit to the indoor unit.
- The suction pipe (the bigger tube), transporting the gaseous refrigerant from the indoor unit to the outdoor unit.

Condensate (humidity from the cooled indoor space) is led from the indoor unit to the outside with the use of a drain pipe. Generally, all installed copper refrigerant transfer pipes are subject to insulation.

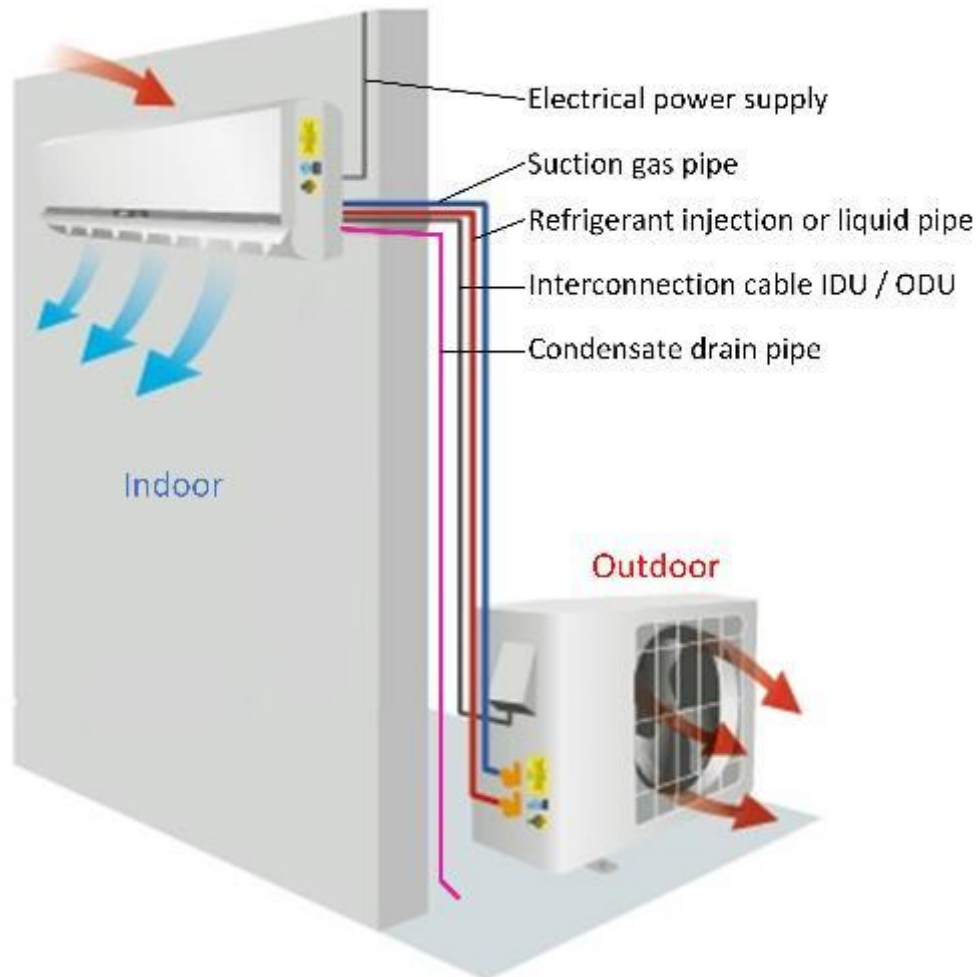

Figure 2: Example of split AC system installation (Source: GIZ)

AC systems are manufactured for a whole range of buildings and therefore made in a range of sizes. Internationally, the most commonly used capacity rating is expressed in Watt, BTU/h, Refrigeration Ton or also Ton of Refrigeration (RT) etc.

Table 1 Cooling and heating capacity conversion table

Unit	BTU/h	Kcal/h	W	KJ	Hp	RT
1 BTU/h	1	0,252	0,239	1,055	0,00039	0,000083
1 Kcal/h	3,968	1	1,163	4,186	0,00155	0,000329
1 W	3,413	0,86	1	3,601	0,00133	0,000283
1 KJ	0,948	0,239	0,278	1	0,00037	0,000079
1 Hp	2559	645	750	2700	1	0,212
1 RT	1200	3024	3516	12660	4,68	1

A2 Ensuring safety

A2.1 Safety bans and warnings

Before starting any job, you must consider how to do it safely. Make sure you know how and when to use personal protective equipment (PPE).

Prepare the site to ensure that it will be a safe site, carefully select and erect the necessary signage appropriate to the task.

Do not allow access to any unauthorised person. During the work, if you become aware of any changes in the area - people coming or going, jobs beginning or ending, you may have to alter your safety precautions.

Be aware of what is happening around you in terms of where you are, where you are supposed to be, and whether anyone or anything around you is a threat to your health and safety.

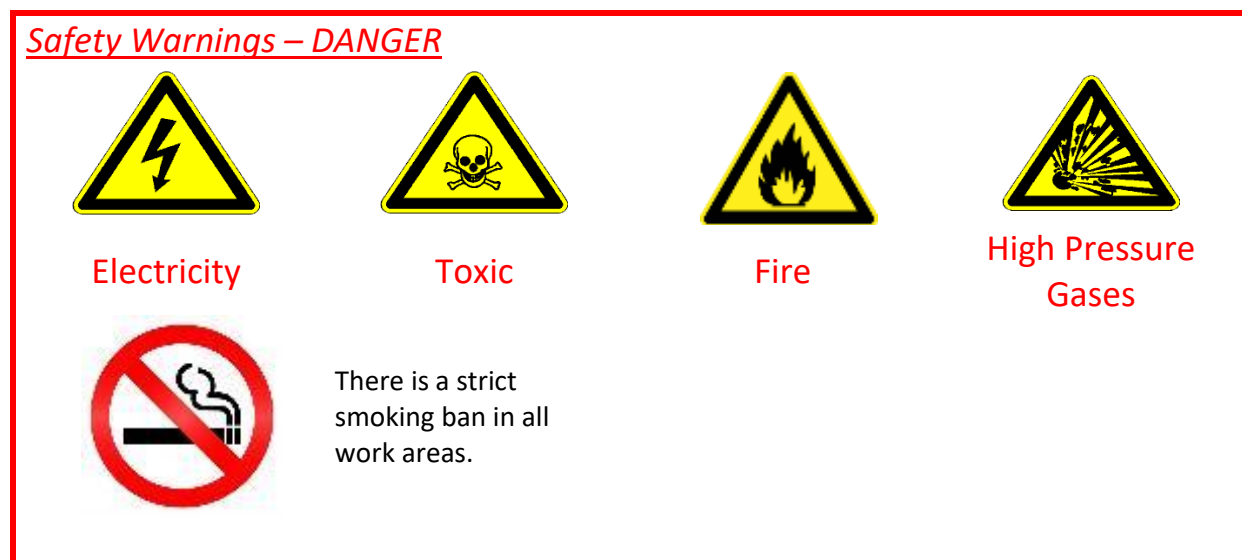

Figure 3: Commonly used safety signage / labels

A2.2 Electrical safety

Most work on a room AC unit by an installer and/or technician needs electricity. The majority of system problems that occur during such installations are electrical in nature. Therefore, technicians must be well aware of potential hazards that exist and precautions to be taken to reduce risk.

- Ground wire must be fitted without fail. In an AC unit it protects from electric shock by allowing current to bypass the body.
- Power tools and extension cords normally have three-prongs; prongs should never be cut off/removed.
- Avoid/remove static electricity. For example, by using ground bracelets or anti-static wrist strap, worn on the wrist and attached to a ground conductor, such as a ground mat or grounding socket safely direct static electricity to the ground.



See Module D for further details on electrical installation and safety

A2.3 Personal protective equipment

Technicians who use hand and power tools and who are exposed to the hazards of falling, flying, abrasive and splashing objects, or exposed to harmful dusts, fumes, mists, vapours, or gases must be provided with the specific personal protective equipment (PPE) necessary to protect them from the hazard.

Technicians and training institutions have a responsibility to work together to establish safe working procedures. If a hazardous situation or a near miss is encountered, it should be brought to the attention of the appropriate individual immediately.

During operation and handling of the equipment, **ALWAYS** wear:



Figure 4: Personal protective equipment

A2.4 Safe handling of installation tools and equipment

Basic tool safety rules

- Maintain regularly
- Inspect before use
- Use the correct tool for the job
- Operate tools according to manufacturers' instructions
- Use the correct Personal Protective Equipment
- Use guarding materials to protect technicians from moving machinery, e.g. belts
- Technicians are responsible for safe condition of tools and equipment and they have the responsibility for properly using and maintaining tools
- Training institutions should caution technicians that hacksaw blades, knives, or other tools be directed away from walkways and other technicians working in close proximity
- Knives and scissors must be sharp - Dull tools can be more hazardous than sharp ones



Examples of tube bender and tube cutters (Source: HEAT GmbH)

Module A: Placing and mounting of AC system components

Power tools – Precautions

- Disconnect tools when not in use, before servicing and cleaning, and when changing accessories
- Keep people from unnecessarily entering the work area
- Secure work with clamps or a vice, leaving both hands free to operate the tool
- Do not hold the switch button while carrying plugged-in tool
- Keep tools sharp and clean
- Remove damaged electric tools and tag them: **“Do Not Use”**

Power tools – Precautions (Electric Cords)

- Do not carry/pull portable tools by the cord
- Do not use electric cords to hoist or lower tools
- Do not pull cord to disconnect it
- Keep cords away from heat, oil, and sharp edges
- Replace damaged cords immediately!

A3 Installation site

A3.1 Ambient temperature

High ambient temperature means the indoor unit has more heat energy to remove from the room and also it will be more difficult for the outdoor unit to reject the heat energy into the atmosphere.

- The outdoor unit, ideally, should be installed so that it is out of direct sunlight. This will help it to reject the heat energy.

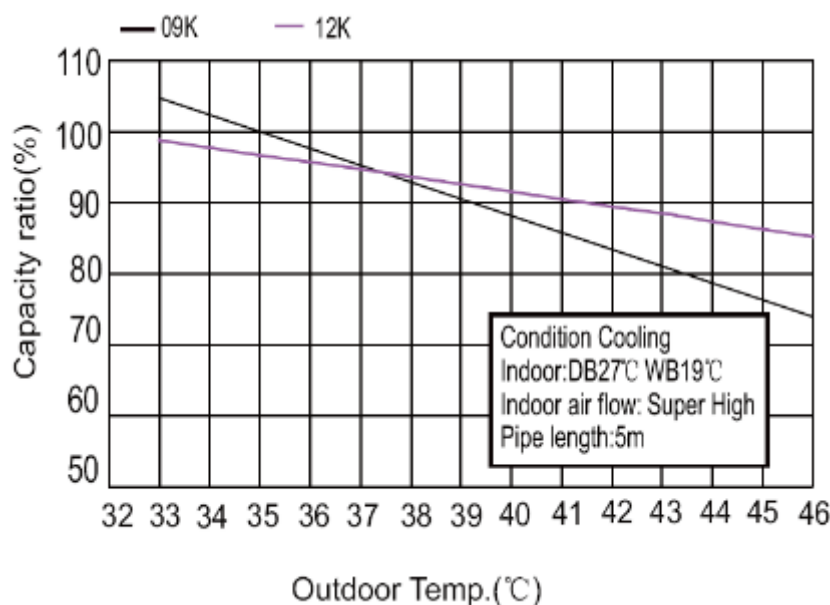

Figure 5: Exemplary relation of outdoor temperature and cooling capacity (Source: GREE)

A3.2 Installation considerations for indoor unit

Always follow the specifications and instructions in the manufacturer’s installation manual.

Module A: Placing and mounting of AC system components

The evaporator needs a good airflow, so that it can absorb as much heat energy as possible from the room it has to cool. The indoor unit with regular heat exchanger protection should not be installed in areas with salty or other aggressive air contaminations. Check if additional protection is necessary.

To ensure best functionality, the indoor unit should be:

- installed so that the airflow is not restricted (provides good air-circulation).
- positioned away from a heat or steam source.
- positioned in distance (about 1 m) from microwave, TV, radio or other electronic devices.
- installed away from combustible objects (for example clothing, curtains, packaging materials).
- at the best place for easy connection with the outdoor unit (ODU).
- at a place for easy connection with condensate drain.
- installed with air-inlet and outlet kept at a far distance from the possible blockage
- mounted on a place solid enough to carry the weight of the IDU and not cause any vibration.

A3.3 Installation considerations for outdoor unit

- Always follow the specifications and instructions in the manufacturer's installation manual.
- The compressor and condenser need a good airflow over them to keep them as cool as possible and have good heat-transfer capability with the environment.
- Ensure that the mounting base, ceiling or the wall is solid enough to carry the weight of the system which will be mounted on it.
- The outdoor unit must be fixed to a flat, stable location. Thereby pay attention that in the installation location there is no possibility of snow, foliage or dirt accumulating
- The operating noise and air flow should not bother neighbours
- It should be placed away from any flammable materials.
- Make sure that appropriate measures are taken against noise emissions, especially when the system is to be installed close to sensitive facilities (such as hospitals and hotels)
- Insulate all tube connections professionally to avoid formation of water condensation and water damage to the rooms or building structures.
- Take care of further requirements to protect the system from damage by earthquakes, hurricanes or high winds. The outdoor unit must not be exposed to rain or direct sunlight.
- Generally, the outdoor unit's rejected air should not counter flow with wind direction (specifically for installation at seaside).
- Never place outdoor unit's air-flow direction in series, this will lead to interference of each other.
- If there is a shade and rain protection above the outdoor unit (canopy), it will improve its performance and lifespan.
- Avoid locating the outdoor unit where it would be exposed to salty atmosphere (or other aggressive air contaminations).

A3.4 Installation site draft sketch

When you have chosen a location – paying attention to the aspects on installation requirements and the points in M4 – and make a sketch of the installation site for the indoor unit.

Your sketch should note the position of the indoor and outdoor unit complete with dimensions.

Module A: Placing and mounting of AC system components

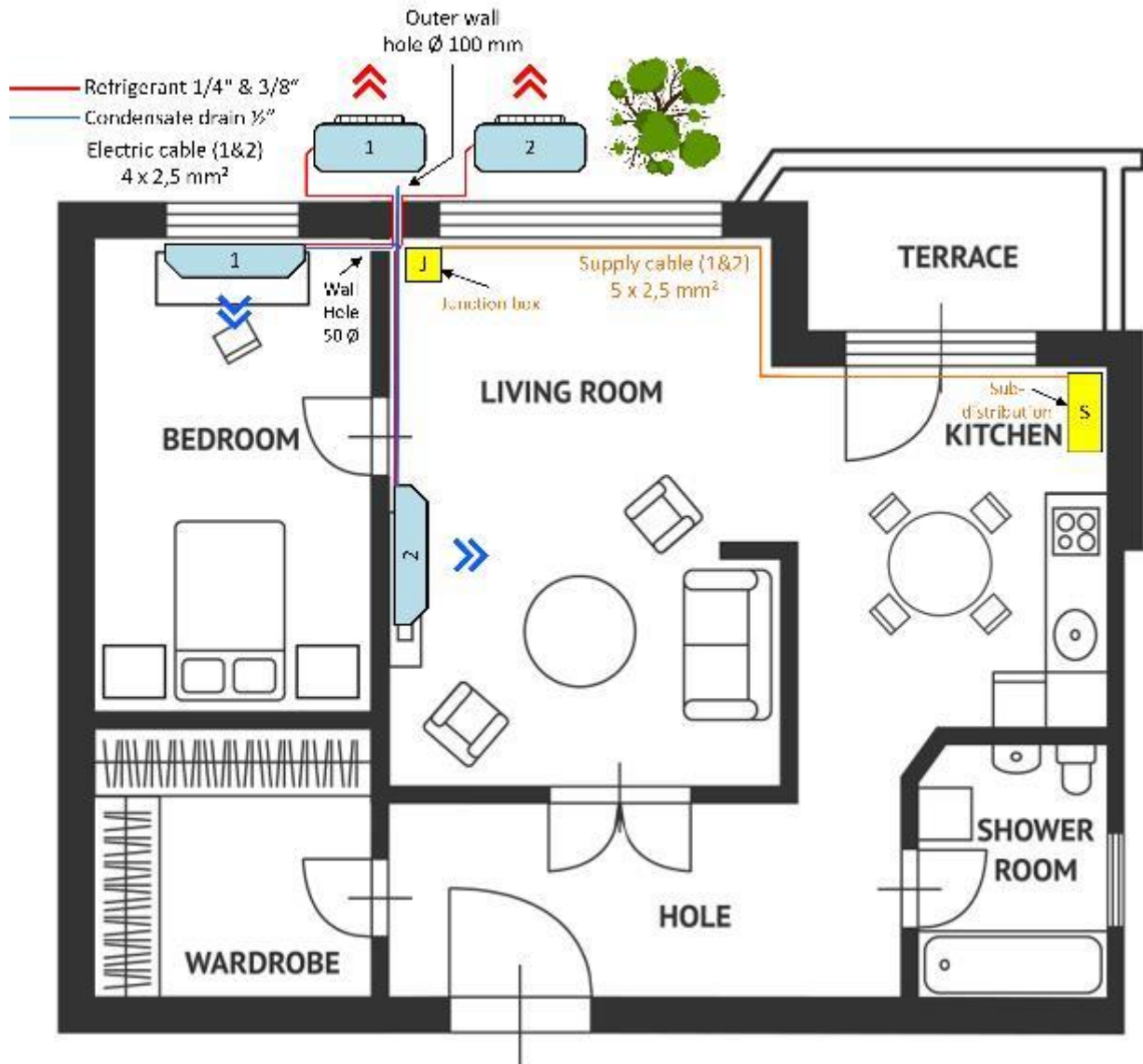

Figure 6: Example of installation site draft sketch (Source: HEAT GmbH)

- There should be adequate space, more than 150 mm, around the indoor unit
- The distance between the ceiling and the indoor unit should be more than 50 mm in the case of front suction or grille design and more than 150 mm in the case of top suction or flat front panel design.
- For the drain, the tube should slope towards the outside of the wall
- The tubing should be as described within the manufacturer's installation instructions (maximum length of tubing, tube dimensions, maximum difference in altitude (between indoor unit and outdoor unit)).
- Tubing should have minimum bends and elbows.
- Tubing materials should be from refrigeration grade material only (see also module F).
- With final installation, the refrigerant transfer pipes, condensate drainpipe and electrical connecting cable (indoor unit / outdoor unit) shall be combined in a bundle and wrapped completely with tape. This in order to protect it against solar UV radiation, aggressive environment and mechanical damage.

Module A: Placing and mounting of AC system components

- A hole should be drilled in the wall for the drain tube, refrigerant tubes and electrical cable, based on all these mentioned aspects. Note the hole size and position on your sketch.

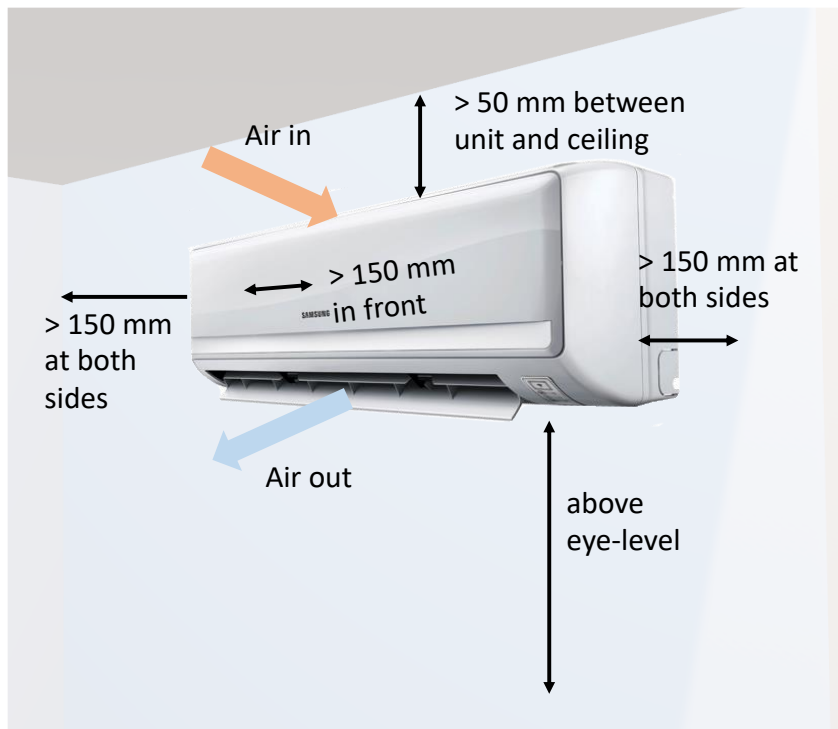

Figure 7: Example of correct location of indoor unit (Source: HEAT GmbH)

Include in your sketch details of how and where you intend to fit the outdoor unit - paying attention to the points raised earlier about airflow and the points mentioned in paragraph A3.3 above.

- For quality installation of outdoor unit, a strong foundation is required, away from direct heat.
- The space around the outdoor unit must be more than 150 mm each side and 250 mm to the rear and more than 1500 mm in front of the unit.
- Position the outdoor unit so that the tubing will have minimum bends and elbows.

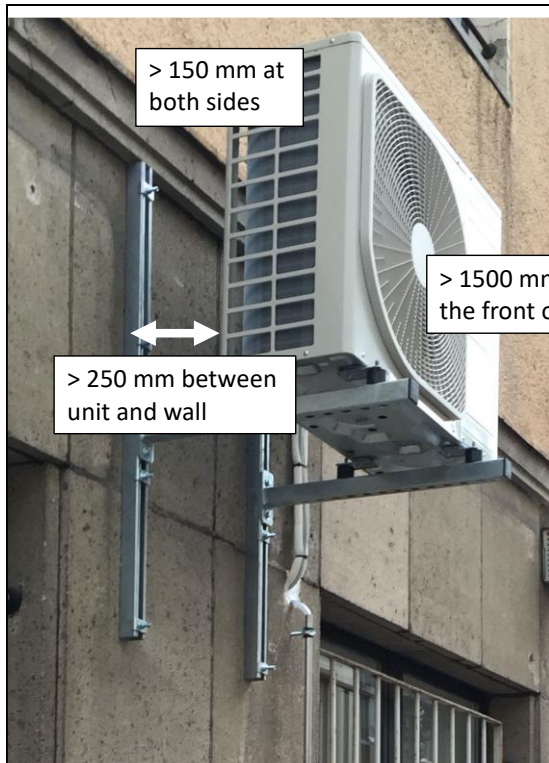

Figure 8: Example of adequate outdoor unit wall installation (Source: HEAT GmbH)



Figure 9: Example of inadequate outdoor unit installation (Source: HEAT GmbH)

A4 List of required materials and tools

The items on the following list are essential for any installer of AC equipment:

- Pencils and marker pens
- Screwdriver set
- Torque wrench
- Adjustable wrench
- Knife or wire stripper
- Steel tape measure
- Spirit level
- Hacksaw
- Plugs (to screw in to when securing the indoor unit to a wall)
- Screws (to secure indoor unit bracket to the wall)
- Fasteners (to secure outdoor unit brackets to the wall and / or outdoor unit to base)
- Masonry drill bits
- Core bits for drilling

Module A: Placing and mounting of AC system components

- Hammer
- Drilling machine
- Tube bender
- Refrigeration (thermal) insulation tape
- Insulated crimps for connecting wire
- Putty
- Clamps or saddles to protect refrigerant tubes
- Drain tube for condensate
- Clamps or saddles to secure condensate drain
- Tape for wrapping the pipes and cable bundle

A5 Step by step placing and mounting of a window AC

A5.1 Supplies check

Before starting work, carefully unpack the AC unit and check that all parts are present and not damaged.

For a window AC unit, the following should be present:

- Insulation foam (for filling any gaps between the unit and the hole in the wall/window)
- A spacer (for adjusting a window size to fit the unit)
- The window AC unit complete with power lead
- Documentation

A5.2 Preparation, positioning and installation of window AC

Installers must be skilled technicians, i.e. competent persons according to the definition provided in M1. Prior to installation of an AC, ensure to get pre-requisites completed by customer. For example, an exclusive power supply must be provided, the house must be suitably wired (no loose contacts/connections) and a correct size opening for the AC must be available.

Check for:

- Exclusive electrical power point (phase line on the right) with circuit breaker;
- Neither a common power point, nor extension to original cable/wire
- Thin house wiring and loose contacts/connections (as it may lead to voltage drop and/starting problems.)
- Ensure wiring to be of 1.5 mm² and 2.5 mm² for up to 3.5 kW (12,000 BTU/h) and 5.25 kW (18,000 BTU/h) capacity
- Select the location as per guidance and free for air circulation
- Ensure an opening ready of correct size with wooden frame of required size
- Unpack and check for any transit/handling damage
- Wall thickness to be 220 mm and if thinner, provide external supports.

Location for the window AC:

- Safe and suitable opening/workplace and strong wall - 220 mm
- Safe to children, away from direct heat/sun, when possible
- External part of the unit to be under shade/awning
- Installation position to be remote from (>1500 mm) video equipment like TVs

Module A: Placing and mounting of AC system components

- Walls be free from any dampness and preferably installation done in the center of the wall
- Bottom of unit above 1500 mm and top not beyond 2000 mm from floor
- Opening in frame be of Height x Width = (Height x Width of Window AC) + 2 to 4 mm
- The distance of obstruction (such as a wall or fence) from the back of the exterior cabinet must be over 500mm
- From sides and top of the exterior cabinet must be over 150mm
- From the top of the interior cabinet must be over 150mm
- From sides of the interior cabinet must be over 500mm

Installation of window AC

- Place unpacked unit with its accessories safely on worktable
- Remove grille and filter etc.
- Remove cabinet-base tray locks
- Pull out base tray/unit from the cabinet
- Install cabinet inclined backward/outward slightly (4-6mm)
- Drill holes on mounting frame (6mm \varnothing) (according to manufacturer's instructions)
- Fix outer cabinet firmly to the mounting frame
- If required, apply grease to bottom of base tray and channels
- Slide base tray into outer cabinet with adequate care of all tubes
- Fill thermal insulation between outer cabinet and wooden frame
- Ensure proper and clean appearance of installed unit
- Fit anti-theft locks if provided with the air-conditioner
- Install the filter, grille and drain tray etc. to base tray from outside
- Connect power cord to power point and switch-on unit
- Set control panel as desired and start the air-conditioner
- Permit air-conditioner to run for about 20-25 minutes
- Demonstrate effective use/benefits, communicate with customer and explain features
- Fill-up warranty documents
- Record all observations as a report and fill-up checklist
- Confirm all accessories are fitted and handover left-over materials
- Clean installation site

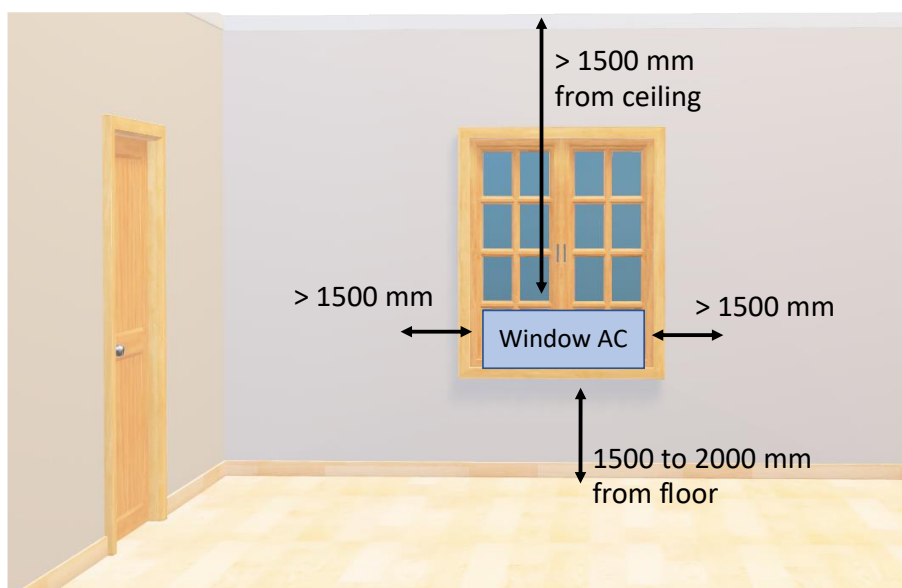

Figure 10: Positioning dimensions when fitting a window AC (Source: HEAT GmbH)

A5.3 Window AC installation protocol

On the completion of the installation of the window AC, a form, such as the example below, should be completed. This document is a check list to ensure that all parts of the installation have been carried out where applicable.

This form should be completed, and a copy handed over to the customer on completion of installation and a copy retained for your company records.

Module A: Placing and mounting of AC system components

Table 2 Installation Protocol (Source: HEAT GmbH)

Installation Protocol

Window type air- conditioner

Installation Company's Name			
Address			
Tel #			
Technician's Name			
Customer's Name			
Address			
Tel #			
Model #		Serial. No.	
Date of Installation		Time:	
	Completed by the installation technician		Completed (check yes or no)
Work carried out	Install cabinet inclined backward/outward slightly (4-6 mm)		YES/NO
	Fix outer cabinet firmly to wooden frame		YES/NO
	Slide base tray into outer cabinet with adequate care of all tubes		YES/NO
	Fill thermal insulation between outer cabinet and wooden frame		YES/NO
	Ensure proper and clean appearance of installed unit		YES/NO
	Fit anti-theft locks (if provided with the air-conditioner)		YES/NO
	Install the filter, grille and drain tray etc. to base tray from outside		YES/NO
	Connect power cord to power point and switch-on unit		YES/NO
	Set control panel as desired and start the air-conditioner		YES/NO
	Permit air-conditioner to run for about 20-25 minutes.		YES/NO
	Demonstrate effective use/benefits, explain features		YES/NO
	Fill-up warranty documents		YES/NO
	Record all observations as a report and fill-up checklist		YES/NO
Confirm all accessories are fitted and handover left-over materials		YES/NO	
<u>Place and date:</u>	<u>Signature of technician:</u>	<u>Signature of client:</u>	

A6 Step by step placing and mounting of a split AC

A6.1 Split AC supplies check

Before starting work, carefully unpack the AC unit and check that all parts are present and not damaged.

For a split type AC unit, the following should be present:

- Bracket for indoor unit (usually packed on the back of the indoor unit)
- Indoor unit complete with insulated pipes and electrical cable (hidden behind unit) but front cover removed
- Outdoor unit (comes precharged with refrigerant)
- A remote control unit and documentation

Items with a split AC system



Figure 11: Bracket (Source: HEAT GmbH)



Figure 12: Indoor unit (Source: HEAT GmbH)



Figure 13: Outdoor unit (Source: HEAT GmbH)

A6.2 Indoor unit

To install indoor unit, check for:

- Strong wall to bear the weight of the unit
- Proximity to power point
- Unit not exposed to any direct radiation/sunlight and can be serviced easily
- Free from obstruction for air-circulation - supply and return air
- Adequate space around the left and right of the unit, should be more than 150mm
- At least 50/150mm from ceiling in case of grill/flat panel
- Convenient access for drainage of condensate
- Prevention of noise/vibration
- Away from flammable materials
- Minimum bends and shortest length of all pipes
- All pipes (refrigerant and condensate drain) shall have insulation

When installing a split system, ensure you check the maximum height difference that the indoor unit can be installed above or below the outdoor unit and also check the maximum length of total pipe run that is allowed between the indoor unit and the outdoor unit. This information is provided in the **manufacturer's documentation**.

To install indoor unit:

- If available, use a master plate for marking of fixation points and wall break through
- Align installation bracket on the wall, checking alignment with a spirit level horizontally and mark the appropriate number of locations for fasteners
- Remove bracket and drill 6 mm holes at marked places, insert sheath/plugs and fit the installation bracket with eight screws.



Figure 14: Example of master plate for installation orientation (Source: <http://aroundhomediy.com>)



Figure 15: Mounting the installation bracket (Source: <http://aroundhomediy.com>)

Module A: Placing and mounting of AC system components

- Break plastic pipe hole cover as per suitable direction for drainage
- Drill hole for tubing, wire etc. 70-100 mm ϕ for 3.5 kW (12,000 BTU) and 5.25 kW (18,000 BTU) units respectively [NOTE: The holes must be slightly sloping towards outdoor side (4-6 mm), see Figure 16]

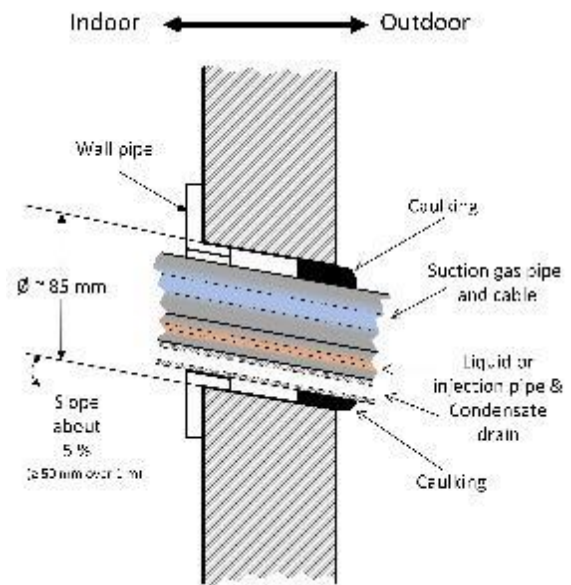

Figure 16: Details for drilling and preparation of the hole through wall (Source: HEAT GmbH)

- Drill the tubing hole on right or left side of installation plate as suitable for the drain line (Figure 17).
- Fit special conduit for allowing tubes to come out smoothly.
- Connect electrical cable to indoor unit.



Figure 17: Drilling the tubing hole through the wall (Source: <http://aroundhomediy.com>)

Module A: Placing and mounting of AC system components

- Lift indoor unit and carefully guide pipes and electrical cable through hole in the wall (see Figure 18) for best positions for pipes and cables).
- Hang indoor unit on to top of bracket
- Clip bottom of indoor unit on to bracket (the indoor unit should cover the hole through the wall)



Figure 18: Indoor unit goes towards bracket, covering the hole through the wall (Source: <http://aroundhomediy.com>)

A6.3 Electrical connections

Figure 19 is an example of the sort of electrical connections required when installing a split AC system. The electrical connections between the indoor unit and outdoor unit are normally made with a four-core cable connected as in Figure 19.

A double pole switch can be inserted in the live and neutral wires, which enables the power to be isolated from the indoor unit. The brown and blue wires provide power to the indoor unit, the black wire is used as a communication cable (so that the indoor unit and outdoor unit know what each other is doing) and the (usually) green and yellow provides an earth connection.

Then electrical power is supplied to the outdoor unit via a three-core cable, brown being line (L), blue neutral (N) and usually green and yellow for earth (E).

Module A: Placing and mounting of AC system components

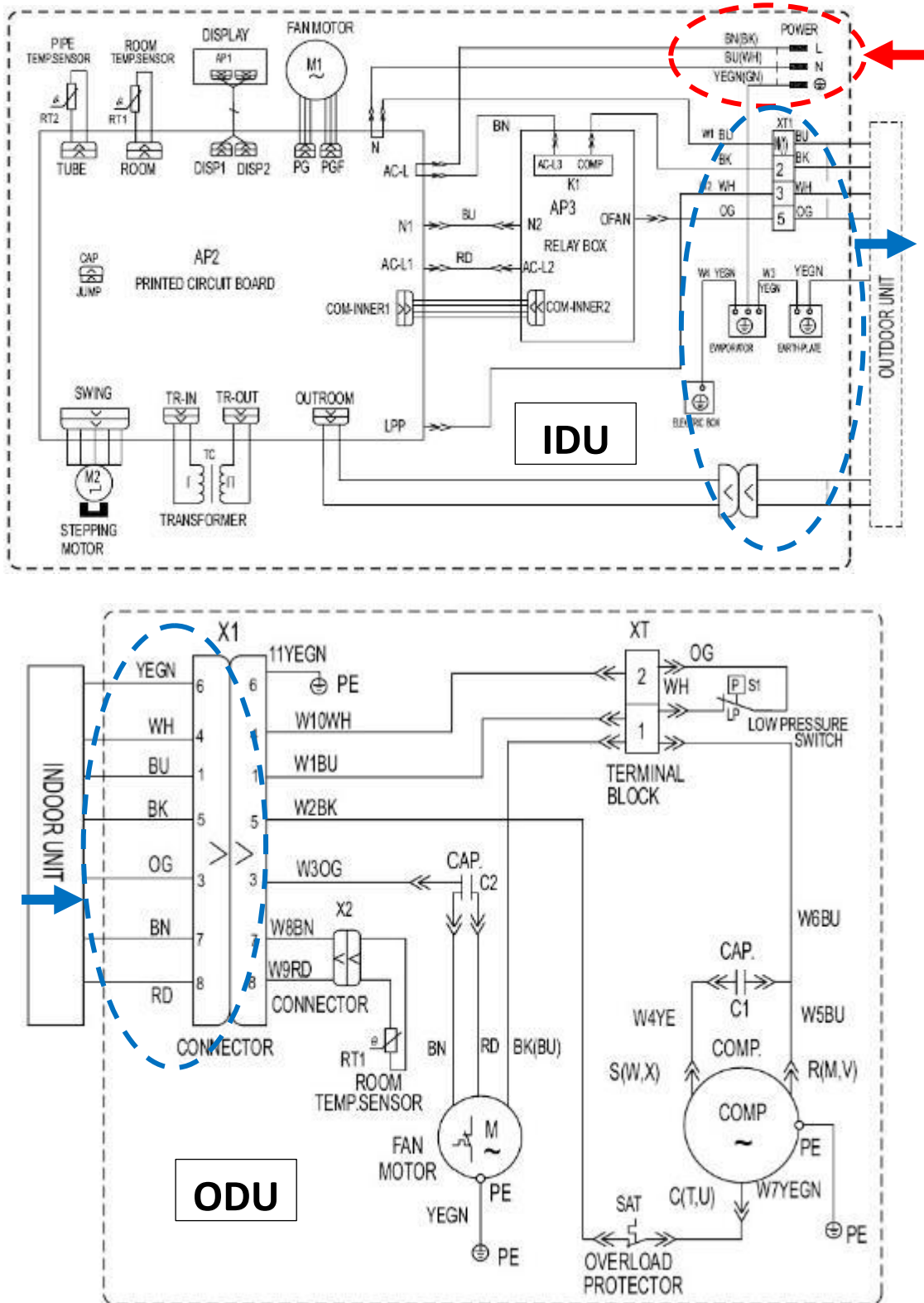

Figure 19: Example of electrical connections between the indoor unit and the outdoor unit (Source: GREE)

Module A: Placing and mounting of AC system components

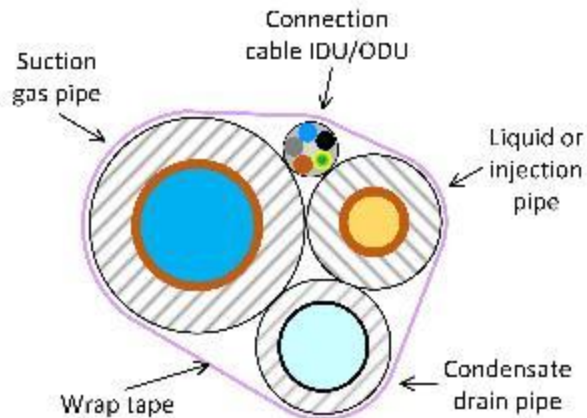

Figure 20: Ideal positioning of electrical cable and pipes through hole in the wall, all tubes are insulated (Source: HEAT GmbH)

A6.4 Outdoor unit

To install the outdoor unit, check for:

- Installation area protected against surrounding pollution (dust, leaves, pollen, etc.)
- If several ODUs to be installed, installation in series should be avoided (see figure below). The exhaust of one ODU must not be allowed to flow through the adjacent unit.
- Select a place which is free of obstacles near the air in- and outlet
- There should be sufficient space at the ODU to allow regular maintenance activities
- Solid foundation to bear the weight and vibration of the unit
- Free space around the unit - back and sides is more than 250/150mm
- Space in front of unit to be more than 1500mm
- Adequate space for ventilation around the unit is available
- Simple installation - for tubing, wiring, drainage and servicing/repairs
- Avoiding strong winds from opposite direction
- No storeroom of flammable gases near unit
- Running noise/vibration and exhaust not disturbing neighbors
- Site not exposed to salty atmosphere
- Awning/shed above unit

To install outdoor unit:

WARNING: The outdoor unit will be pressurised with refrigerant. Take care when handling the outdoor unit. DO NOT open the service valves fitted to the outdoor unit. (See Figure 21)

- Ensure rigid base for installation of outdoor unit or install rigid wall brackets on to strong wall
- In case the site is in heavy breeze area or high height/altitude, install outdoor unit lengthwise along the wall-using shield to protect working of fan
- If the drainage is bad or if the water is likely to accumulate near the outdoor unit, place the outdoor unit on the concrete block or raised platform, if possible
- If the outdoor unit vibrates too much, adjust the angle of the installation legs and in case the unit is likely to tilt or fall, bolt it to the base with minimum of 8 mm \varnothing anchor bolts (depending on the weight load of the system)

Module A: Placing and mounting of AC system components



Figure 21: Example of service valves fitted to the outdoor unit (Source: www.espasogutma.com)



Figure 22: Example of outdoor unit showing typical refrigerant pipe connections (Source: HEAT GmbH)

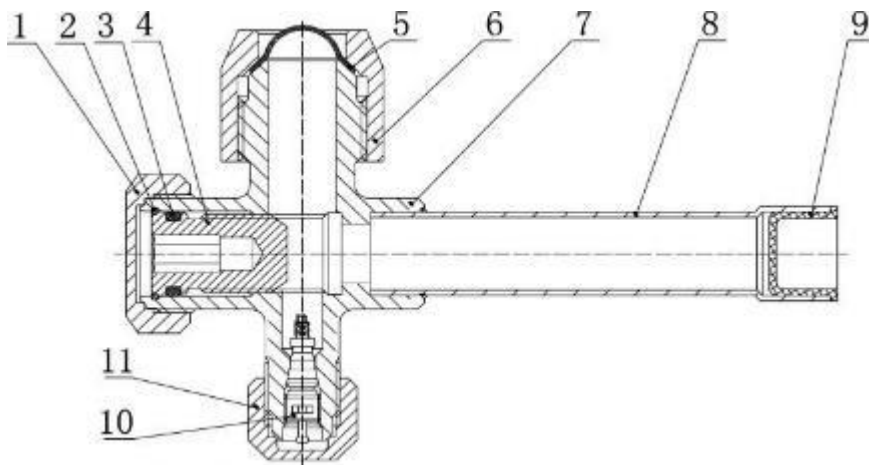

No.	Designation
1	Valve cap
2	Stop collar
3	O-ring
4	Valve stem
5	Sealing cap
6	Flare nut
7	Valve body
8	Copper tube
9	Internal outdoor unit connection
10	Valve core (schrader)
11	Swivel nut

Figure 23: Indication of service valve elements and designation unit (Source: www.espasogutma.com)

Module A: Placing and mounting of AC system components



Figure 24: Outdoor unit electrical and pipe connections cover (Source: HEAT GmbH)



Figure 25: Example of outdoor unit showing service valves and interior components (Source: HEAT GmbH)



Figure 26: Examples of adequate electrical connections in outdoor unit (left) and indoor unit (right) (Source: HEAT GmbH)



Figure 27: Example of inadequate electrical connections - no cable hoes or end splices (Source: HEAT GbmH)

Connect the indoor unit to the outdoor unit:

For some cases, with delivery of the split AC unit components, the system is equipped with a pipe and cable set consisting all materials for indoor unit and outdoor unit interconnection (copper tubes, condensate drain tube, electrical cables).

- Carefully remove the blanks fitted to the indoor unit copper pipes (always use 2 spanners, to avoid twisting the soft copper tubes)

WARNING: The indoor unit will be pressurised with a holding charge of oxygen free dry nitrogen (OFDN), as the blanks are removed this nitrogen will be released. Ensure the blanks are removed in a safe manner.

- The tightening surfaces of copper tube flared joints must be free of grease, lubricant or any other contaminations prior to connecting to indoor unit pipe connections
- Connect both refrigerant pipelines to indoor unit and ensure both connections are loosely tightened with two spanners
- **DO NOT insulate the pipe joints** (this will allow the skilled craftsman/woman to check the joints for leaks)

NOTE: The skilled craftsman/woman will torque tighten the connections as per Table 3 prior to tightness testing

Table 3 Torque tightening values

Nominal outside diameter (according to EN 12735-1 and EN 12735-2)		Minimum wall thickness (mm)	Tightening torque (Nm)	
Metric series (mm)	Imperial series			
	(mm)	(in)		

Module A: Placing and mounting of AC system components

6			0.80	14 - 18	
	6.35	$\frac{1}{4}$	0.80	14 - 18	
	7.94	$\frac{5}{16}$	0.80	33 - 42	
8			0.80	33 - 42	
	9.52	$\frac{3}{8}$	0.80	33 - 42	
10			0.80	33 - 42	
12			0.80	50 - 62	
	12.7	$\frac{1}{2}$	0.80	50 - 62	
15			0.80	63 - 77	
	15.88	$\frac{5}{8}$	0.95	63 - 77	
18			1.00	90 - 110	
	19.06	$\frac{3}{4}$	1.00	90 - 110	

- Carefully bend each of the copper tubes to obtain a neat appearance and to meet up with connections on outdoor unit. **For detailed information on copper tube bending, refer to A7.**
- If there is an excess of copper tube, coil up the excess with a \varnothing of approximately 12" and secure neatly against the outside wall
- **ONLY** use pipe sets with industrial manufactured flares
- Carefully remove the flare nuts fitted to the outdoor unit service valves (refer to Figure 23)
- Connect copper tubes flare nuts to outdoor unit service valves and ensure both connections are loosely tightened with two spanners
- **DO NOT insulate the pipe joints** (this will allow the skilled craftsman/woman to check the joints for leaks)
- Fill any remaining space in between the pipes and cable passing through the wall with putty

NOTE: The skilled craftsman/woman will torque tighten the connections as per Table 3 prior to tightness testing

Condensate drain

- Cut suitable lengths of PVC condensate drain tube
- Fit together PVC condensate drain tube and fittings (e.g. elbows) to ensure the condensate drains to a suitable place
- Check fitting and alignment of drain tube and fittings when connected to condensate drain from indoor unit and adjust as necessary
- Once happy with the fit, glue together the drain tube and fittings
- Fit and secure drain tube to wall using suitable saddles

Electrical power supply pre-installation

- Route electrical cable from indoor unit to outdoor unit. Ideally, hide it behind copper tubing and insulation to ensure cleanliness and protection from the weather.
- Secure electrical cable to copper pipe and insulation
- Connect electrical cable to outdoor unit (see Figure 18)
- **Secure all cables firmly with the pull relieve!**
- Ensure adhering to colour codes of the wires and use only suggested wires
- Refer to standard wiring diagram pasted inside unit (and outdoor unit)

Module A: Placing and mounting of AC system components

- Ensure earthing is provided at the earthing points on indoor and outdoor units
- Do not allow the wires inside the cable to touch the refrigerant tubing, compressor etc.
- Place batteries in remote controller as necessary.

A6.5 Split AC installation protocol

On completion, an installation document, such as the one below, should be completed to inform both the customer and the skilled craftsperson (competent person for refrigerant handling activities) doing the commissioning that the system has been correctly installed.

The skilled craftsman/woman also needs to know what work has been carried out and what needs to be completed as part of the commissioning process.

So it is the responsibility of the skilled craftsperson to ensure that the following document has been correctly filled out, a copy given to the customer and a copy left with the AC system requiring the work (ensure that the document is protected by leaving it with the owner of the equipment).

Module A: Placing and mounting of AC system components

Table 4 Installation protocol for split AC system (Source: HEAT GmbH)

Installation Protocol

Split type air- conditioner

Installation Company's Name			
Address			
Tel #			
Technician's Name ① - Installation			
Technician's Name ② - Commissioning			
Customer's Name			
Address			
Tel #			
Model #		Serial. No.	
Date of Installation		Time:	
	Completed by the installation technician	Completed (check yes or no)	
Work carried out	indoor unit installed	YES/NO	
	outdoor unit installed	YES/NO	
	Refrigerant pipework installed and loosely tightened flare nuts at both ends	YES/NO	
	Condensate drain pipework fitted	YES/NO	
	To be completed by skilled craftsman/woman	Completed	
Remaining work required	Torque tighten 4x refrigerant pipe connections	YES/NO	
	Test condensate drain	YES/NO	
	Strength test refrigerant pipework	YES/NO	
	Tightness test refrigerant pipework	YES/NO	
	Evacuate refrigerant pipework and indoor unit	YES/NO	
	Finish insulating pipework (over flare nut connections)	YES/NO	
	Open both service valves on outdoor unit to release refrigerant into refrigerant pipework and indoor unit	YES/NO	
	Electric safety check	YES/NO	
Test AC unit and final leak check	YES/NO		
<u>Place and date:</u>	<u>Signature of technician (1) & (2):</u>	<u>Signature of client:</u>	

A6.6 Post installation check-up

- Are indoor and outdoor units installed securely?
- Is enough space provided around the units for efficient performance?
- Is anything obstructing air circulation?
- Are tubes insulated sufficiently and properly?
- Is the pipe and cable bundle wrapped with tape correctly?
- Are all gaps around unit and tubes hole filled with thermal insulation?
- Is care taken to avoid abnormal noise, vibration and dripping?
- Are electric wires used as per requirements?
- Is earthing wire connected to the units properly?
- No leakage of refrigerant
- Is the drainpipe extended with commercial rigid PVC?
- Does drain flow out smoothly? (The simplest way to test this is by pouring the water into the condensate drain pan after the installation or assembly of the indoor unit and looking at the water drainage flow. If the water falls inside, this shows that drain slope is not correct. If all the water flows outside the drain, this means that the slope is well maintained.

Wipe clean both the indoor unit and outdoor unit and remove any dust, dirt and oil spills.

Remove any waste materials from the site and ensure that the installation site is left clean and tidy.

At this point, the job of the installing technician is completed. The skilled craftsperson (doing the commissioning) will be required to carry out the following tasks either during the installation or at some later date before the system can be used:

- Torque tighten the 4 x refrigerant pipe connections
- Test the condensate drain
- Strength test the refrigerant pipework
- Tightness test the refrigerant pipework
- Evacuate the refrigerant pipework and indoor unit
- Finish insulating pipework (after satisfactory tightness test)
- Open both service valves on outdoor unit to release refrigerant into refrigerant pipework and indoor unit
- Carry out an operational test of the AC system and final leak check

A7 Refrigerant circuit tubing

A7.1 Importance of good pipework

The pipework between indoor unit and outdoor unit should be correctly bent, with the minimum of bends possible (because each bend causes a restriction in the refrigerant flow) and both pipes should be thermally insulated. Refrigerant piping should be routed in the shortest and simplest possible manner.

Flattened bends or damaged insulation will cause malfunctioning of the system. If the refrigeration tubing is flattened while bending during installation, the flow of refrigerant will be affected, so insufficient refrigerant will be available to absorb the heat energy in the room. If the tubing insulation is damaged, heat from the outside atmosphere will be absorbed by the refrigerant. Therefore, the refrigerant in the room will be too warm to cool the room to the required temperature.

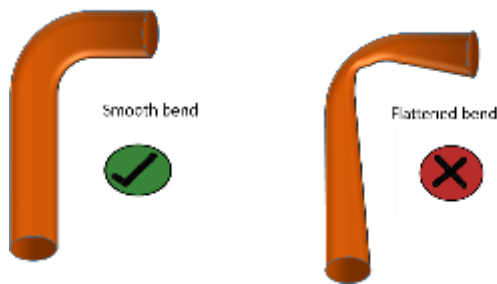

Figure 28: A good bend and a flattened bend
(Source: HEAT GmbH)



Figure 29: Inadequately handled copper tube
(Source: HEAT GmbH)

A7.2 Copper tube

Most installations which use fluorocarbons or hydrocarbons as refrigerants use copper piping. This copper piping must be seamless, de-oxidized and dehydrated.

It is designed as 'refrigeration quality' to EN12735 and ASTM B280-86¹.

- ASTM B280 Standard Specification for Seamless Copper Tube for Air Conditioning and Refrigeration Field Service
- EN 12735 - Seamless, round copper tubes for air conditioning and refrigeration.

It is available in either cold drawn hard, half hard or annealed condition in sizes from 1/8" outside diameter (OD) to 4 1/8" OD, and 12 to 22 standard wire gauge (swg).

Advantages of copper tube

Copper tube has been used worldwide for many years and it is one of the most important and reliable metals used in air conditioning. One of the many advantages of copper tube is that it is easy to cut and bend, form bends with and join to components. Few tools are required for this, a hand bending machine is normally suitable. Therefore, it is possible to eliminate fittings such as elbows and joints. This allows savings in installation time, material and overall costs.

It is strong, long lasting and is the leading choice of most contractors for refrigeration and AC installations in all kinds of residential and commercial buildings. Copper tube is relatively easy to transport and handle because it is lightweight (in comparison to steel tube) and, when installed, takes less space. It has excellent resistance to corrosion, high mechanical strength, high-temperature resistance and lifetime resistance to UV degradation.

Annealed soft copper tube is supplied in sizes from 1/8" to 7/8" OD, 19 to 22 swg, in 10, 15 and 30m coils with ends sealed to preserve dryness. Tubing should be cut from one end of the coil. The remainder is then resealed. This tube is pliable and easily bent by hand using external tube benders but can look unsightly

¹ ASTM International, which was formerly known as the American Society for Testing and Materials, is an international standards organization that develops and publishes technical standards for a range of materials

Module A: Placing and mounting of AC system components

unless care is taken during installation. The tube should be unrolled from the coil to the length required on a flat bench or level surface. The length required is cut with a wheel cutter and the coil re-sealed.

No attempt should be made to re-roll the coil as this 'work hardens' the copper, causing unnecessary stress points. In unrolling the coil, it becomes slightly elliptical in cross-section so it may need the leading end of a swage punch to correct it after de-burring. This tubing can be swaged or flared. Flared fittings and components from ¼" to ¾" diameter are available. Soft copper tube can be "formed" using bending pliers or "external" bending springs to prevent "flattening".

Half-hard copper tube is supplied in 3m and 6m straight lengths from ⅜" to 2½" OD, 14 to 20 swg, with ends sealed to preserve dryness. Tubing should be cut from one end of the tube with a wheel cutter and the remainder resealed.

Cold drawn hard copper tube is supplied in 3 m and 6 m straight lengths from 2⅝" to 4¼" OD, 14 to 18 swg, with ends sealed to preserve dryness. Tubing should be cut from one end of the tube with a wheel cutter and the remainder resealed.

Soft coiled copper tube is annealed to R220 Standard and straight lengths of half hard copper tube to R250 and fully hard to R290. (Under **EN1173**, the temper condition or material strength, is designated with an 'R' number, the higher the number the stronger the material. Soft condition is denoted as R220, half hard R250 and hard R290.)

Metric refrigeration quality copper tubing is available to order from suppliers. **Note: Plumbing grade and size copper tube must not be used under any circumstances.** The thickness of the wall of the piping is not suitable for refrigeration pressures.

The internal cleanliness of refrigeration pipework is of paramount importance. It is this pipework which connects all the system components. Dirt and moisture are most likely to enter the system during the installation of pipework. **Note: Every precaution must be taken to ensure that dirt, air and moisture do not enter the system.**

A7.3 Bending copper tube

When refrigerant flows through copper tube, it must be able to run smoothly with nothing causing resistance to the flow. Best practice is to ensure pipe runs are as straight and direct as possible. A technician must plan the piping layout around the optimum route for the suction line (usually the bigger copper tube). Sometimes bends are unavoidable: When tubing is required to go around a room or change direction, and if available fittings are neither right for the angle nor attractive to look at, then the only solution would be to bend the pipe.

The bending of copper tubes is more economical than using fittings. It also avoids additional leakage potential. Note: Making good effort to achieve this in the beginning is worth it, as it is far easier than correcting the faulty installation later.

If it is necessary to change the direction of the tube, it is cheaper and quicker to bend the pipe than use fittings. This also makes the neatest finish – particularly if the pipework is going to be exposed. Using fittings would be more expensive and the alternative of making bends means the pipework is less conspicuous. The pipe can also be bent to any angle required so this method of changing direction is not limited by the angles of the fittings. Also, with fewer fittings in a pipe system there are fewer places where leaks might occur.

Module A: Placing and mounting of AC system components

The following sections describe bending by hand and using bending tools. The minimum radius for a tubing bend is between 5-10 times diameter of the tubing.

The regular used copper pipe for split air- conditioner installation in sense of this technical manual is annealed, soft, seamless, flexible, and available in longer lengths according to the before mentioned standards. The use of rigid copper pipes is also possible but not subject of this technical manual.

Manual bending

Annealed copper tube can be bend manually by hand, but this may cause flattening of the tube (Figure 29). Any such flattening will create a restriction to the flow of refrigerant and hence cause a pressure drop.

If during manual bending, a pipe is kinked, the technician must cut and discard the kinked section.

Making accurate bends needs some training and practice, but it is cheaper than buying specially shaped fittings like an elbow or long radius bend. Crossover fittings can also be eliminated as these can be formed using a bending machine.

External springs (**Error! Reference source not found.**) are available to prevent flattening of the tube when carrying out manual bends and are available in various sizes up to $\frac{3}{4}$ ".



Figure 30: Copper tube bending springs (Source: HEAT GmbH)

Using an external bending spring reduces the possibility of flattening the tube. It is a relatively quick and easy method for bending copper tube. Bending springs are used to support the tube walls during bending to prevent the walls from collapsing. It is very important to use the correct size spring.

This method needs some practice and the result will not be as neat as using a manufactured bending tool. After completing a bend with a bending spring, the spring will tend to bind on the tube making it difficult to remove. Also, if the tube has flares already made at each end, bending springs cannot be used.

Tube benders

A variety of tube benders are available, but as the size of the tube increases the tube gets more difficult to bend. Small size tubes as used on most split AC systems take little physical effort to bend. Advantages of tube bending machines are that they take account of the tube diameter when creating the bend radius and will not flatten the tube if the tool is used correctly. They also produce a neat bend which is consistent. Every bend produced using the tool will be the same.

Various manufacturers produce different triple size bender which can be useful. Generally, it is important to differentiate between the use of these tools designed for metric or inch sized tubes.

Furthermore, it is important that the tool is designed to perform 180° tube bends and if possible, in one swift action.

There are two common models of triple size tube benders.

1. Triple size bender for (3/16"), 1/4", 5/16" and 3/8" (6 mm, 8 mm and 10 mm)



Figure 31: Example of triple size tube bender size 1 (1/4"; 5/16", 3/8") (Source: javac.co.uk)

2. Triple size bender for 3/16", 1/4", 3/8" and 1/2"

The triple size tube bender type 2 is generally recommended for the installation of split AC systems but only available for inch sized copper tubes.



Figure 32: Example of triple size tube bender size 2 (3/16", 1/4", 3/8", 1/2") (Source: imperial.com)

For larger size tubes, individual bending tools are readily available. An example is shown in Figure 33.



Figure 33: Individual size tube bender (Source: ITE-Tools)

Embossed into the head of the tool are a series of marks which help technicians to produce bends to specific angles.



Figure 34: Angle marks on a tube bender (Source: HEAT GmbH)



Instructions for copper tube bending

1. Raise form lever and position tubing into the guide groove. It is important that the tube is engaged with the tube clamp to prevent tube slippage (see **Error! Reference source not found.**).
2. Lower form lever until the "O's" on the form wheel and form lever are aligned. The degree of bend is indicated when the "O" mark on the form lever aligns with the degree mark on the form wheel (Figure 34)

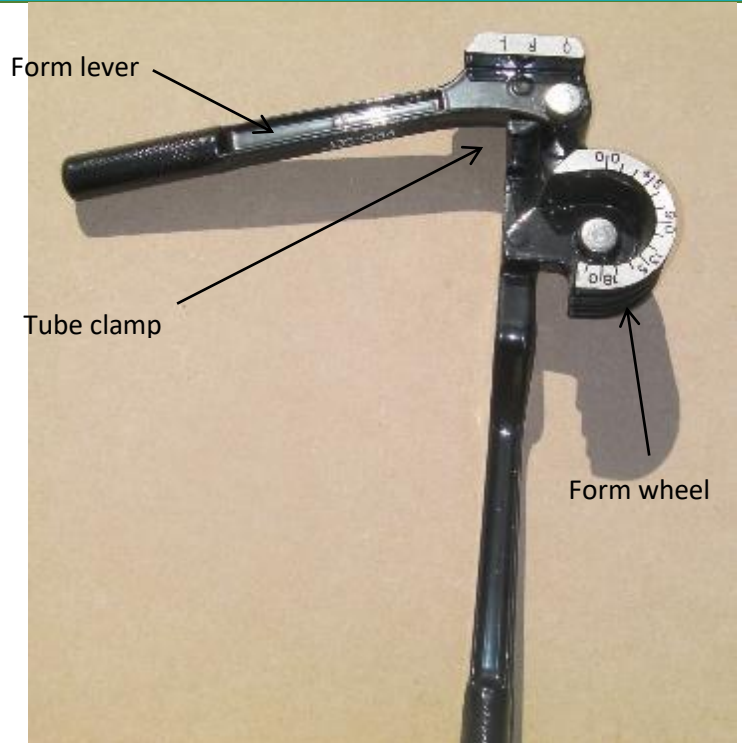

Figure 35: Parts of a tube bender (Source: HEAT GmbH)

180° Bends

1. Measure from the end of the tube to where you want the centre of the bend to be and place a mark on the tubing at the exact point.
2. Position the tube in the bender. If the end from which you measured is LEFT of the tube clamp, the measured mark should be in line with the "L" on the form lever (Figure 34).
3. If the end from which you measured is placed to the right of the tube clamp, the measured mark should be in line with the "R" on the form lever (Figure 34).
4. With a steady motion, pull the form lever round until the "O" mark on the form lever is directly opposite the 180° mark on the form wheel (Figure 34).

90° Bends

1. Measure from the end of the tube to where you want the centre of the bend to be and place a mark on the tubing at the exact point.
2. Position the tube in the bender. If the end from which you measured is LEFT of the tube clamp, the measured mark should be in line with the "L" on the form lever (Figure 34).
3. If the end from which you measured is placed to the right of the tube clamp, the measured mark should be in line with the "R" on the form lever (Figure 34).
4. With a steady motion, pull the form lever round until the "O" mark on the form lever is directly opposite the 90° mark on the form wheel (Figure 34).

45° Bends

1. Measure from the end of the tube to where you want the centre of the bend to be and place a mark on the tubing at the exact point.
2. Position the tube in the bender. If the end from which you measured is LEFT of the tube clamp, the measured mark should be in line with the "L" on the form lever (Figure 34).
3. If the end from which you measured is placed to the right of the tube clamp, the measured mark should be in line with the "R" on the form lever (see Figure 34).
4. With a steady motion, pull the form lever round until the "0" mark on the form lever is directly opposite the 45° mark on the form wheel (see Figure 34).

A7.4 Oil traps for compressor oil-return

Note: Generally, equipment manufacturers installation instructions (pipe dimensioning and routing) must be followed!

With any operation of a refrigerating system, the circulating refrigerant is always "mixed" with the compressors lubricating oil. The refrigerant circuit piping system shall be designed in such a way that oil returns to the compressor at the same rate that it leaves. Special precautions must be taken for the installation of the suction line within the refrigerant circuit. To promote good oil return, suction lines should be inclined 10 mm/m in the direction of refrigerant flow. Depending on the installation location of the outdoor unit (ODU), lubricating oil for the compressor has to travel upwards (suction gas rising pipe) or downwards (suction gas falling pipe). It is recommended to install oil traps within routing of the refrigerant suction pipe as required.

P-trap and S-trap

A P-trap (oil-trap) should be made at the outlet of the evaporator if the suction pipe rises above the bottom of the evaporator. A suction riser is any vertical pipe that has an upward flow of refrigerant. The reason for the suction P-trap is to help the return of oil to the compressor. The refrigerant gas returning from the evaporator will contain drops of oil that can collect and mix in the turbulence of the trap. This turbulent action breaks up the larger drops of oil into smaller droplets carried up to the riser pipe by the gas velocity. A P-trap should be used at the base of any suction riser with greater than 2.5 m in length.

If the pipe is being routed over, around, or under obstacles, this can create unwanted traps in the return line and collect oil. If possible, the refrigerant pipe should travel a direct and straight course between the evaporator and compressor.

In long suction risers, S-trap should be used for every 5 m of vertical suction pipe rise.

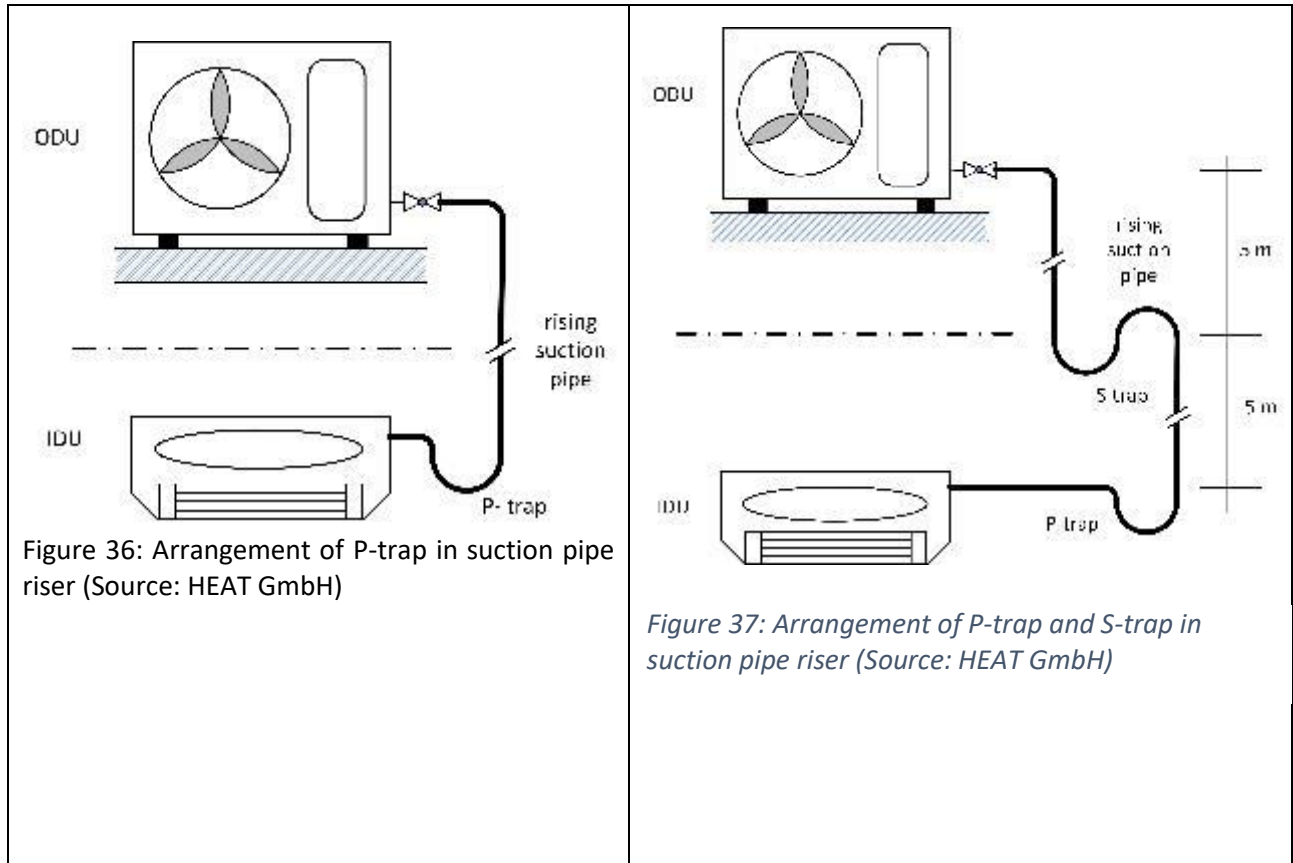

Figure 36: Arrangement of P-trap in suction pipe riser (Source: HEAT GmbH)

Figure 37: Arrangement of P-trap and S-trap in suction pipe riser (Source: HEAT GmbH)

Invert trap

While operating, the suction pipe is filled with superheated refrigerant vapour and oil. The oil flows on the bottom of the pipe and is moved along by the refrigerant gas flowing above it. When the system stops, the refrigerant may condense in the pipe depending on the ambient conditions. This may result in slugging if the liquid refrigerant is drawn into the compressor when the system restarts.

To minimize slugging of condensed refrigerant, the evaporators should be “isolated” from the suction pipe with an inverted trap. The trap should extend above the top of the evaporator before leading to the compressor.

Module A: Placing and mounting of AC system components

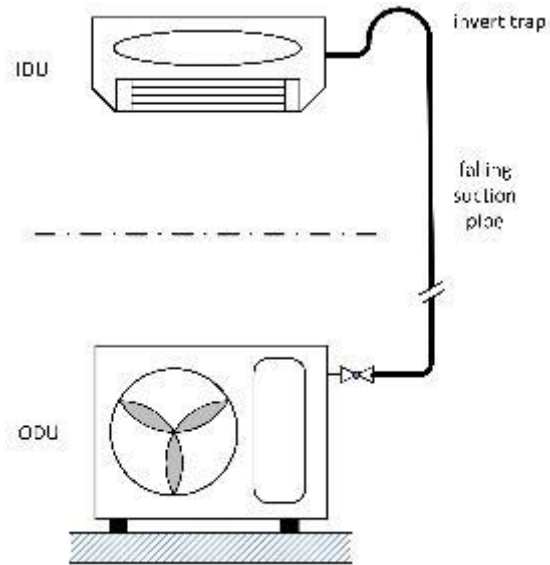

Figure 38: Example of invert trap arrangement within the suction pipe (Source: HEAT GmbH)

Bibliography

Hühren, R., Devotta, S., Juvekar, S., & Padalkar, A. (2013). *Good Practices in Installation and Servicing of Room Air-conditioners. Refrigeration and Air-conditioning (RAC) Technicians Handbook*. GIZ.

Standards referred to in this module:

ASTM B280 Seamless Copper Tube for Air Conditioning and Refrigeration Field Service

EN 1173 Copper and copper alloys - Material condition designation

EN 12735 Copper and copper alloys - Seamless, round tubes for air conditioning and refrigeration

EN 13313 Refrigerating systems and heat pumps - Competence of personnel

ISO 22712 Refrigerating systems and heat pumps - Competence of personnel

Websites referred to in this module:

<http://aroundhomediy.com>

<http://www.ashrae.org/ashraeterms>